



European  
Commission

## JRC TECHNICAL REPORTS

# Preparatory study for solar photovoltaic modules, inverters and systems

*Draft Report Task 4: Technical  
analysis including end-of-life*

Dodd, Nicholas; Espinosa, Nieves – JRC B5

Van Tichelen, Paul; Peeters, Karolien - VITO

Alam, Mohammad Meraj; Aernouts, Tom;  
Gordon, Ivan; Manganiello, Patrizio; Tous, Loic;  
Tsanakas, Ioannis; Voroshazi, Eszter - IMEC

Joint  
Research  
Centre

This publication is a Technical report by the Joint Research Centre (JRC), the European Commission's science and knowledge service. It aims to provide evidence-based scientific support to the European policymaking process. The scientific output expressed does not imply a policy position of the European Commission. Neither the European Commission nor any person acting on behalf of the Commission is responsible for the use that might be made of this publication.

#### Contact information

Nicholas Dodd and Nieves Espinosa

Address: Edificio Expo. C/ Inca Garcilaso, 3. E-41092 Seville (Spain)

E-mail: [jrc-b5-photovoltaics@ec.europa.eu](mailto:jrc-b5-photovoltaics@ec.europa.eu)

Tel: +34 954 488 728/476

#### JRC Science Hub

<https://ec.europa.eu/jrc>

© European Union, 2019

Reuse is authorised provided the source is acknowledged. The reuse policy of European Commission documents is regulated by Decision 2011/833/EU (OJ L 330, 14.12.2011, p. 39).

For any use or reproduction of photos or other material that is not under the EU copyright, permission must be sought directly from the copyright holders.

How to cite this report: Dodd, N and Espinosa, N, *Preparatory study for solar photovoltaic modules, inverters and systems – Task 4 Technical analysis including end-of-life* European Commission, Joint Research Centre, 2019

## Contents

4. Task 4: Technical analysis including end-of-life .....	<del>33</del>
4.0 General introduction .....	<del>33</del>
4.1 Technical product description of PV module, inverter and system solutions.....	<del>33</del>
4.1.1 Crystalline silicon PV wafer and cells technologies.....	<del>55</del>
4.1.1.1 Strict product scope of PV wafer technologies: performance.....	<del>55</del>
4.1.1.1.1 Wafer preparation.....	<del>55</del>
4.1.1.1.2 Silicon material .....	<del>77</del>
4.1.1.2 Strict product scope of PV cell technologies: performance .....	8
4.1.2 Crystalline silicon module technologies and materials .....	10
4.1.2.1 Crystalline silicon module technologies and materials .....	10
4.1.2.2 Strict product scope .....	10
4.1.2.3 Extended product scope: energy generation potential and reliability under non Standard Test Conditions (STC).....	18
4.1.2.4 Recycling of PV modules .....	20
4.1.2.5 Summary and reference data on the performance and cost of the products and technologies described .....	22
4.1.3 Thin-film module technologies and materials.....	25
4.1.3.1 Strict product scope: performance .....	25
4.1.3.2 Extended product scope: energy generation potential and reliability under non Standard Test Conditions (STC).....	26
4.1.3.3 Summary and reference data on the performance and cost of the products and technologies described .....	27
4.1.4 Inverter technologies .....	<del>29</del> <del>28</del>
4.1.4.1 Introduction to grid coupled photovoltaic inverter technology with standard performance .....	<del>29</del> <del>28</del>
4.1.4.2 Introduction to grid coupled inverters with combined battery storage function and prospect for future DC grid applications .....	<del>38</del> <del>36</del>
4.1.4.3 Summary of the technical improvement options and impact on Performance, Bill of Material and product price for inverters .....	<del>40</del> <del>38</del>
4.1.5 PV system level technologies and practices.....	<del>43</del> <del>41</del>
4.1.5.1 Technology selection as a response to real climatic conditions .....	<del>43</del> <del>41</del>
4.1.5.2 PV system design software.....	<del>44</del> <del>41</del>
4.1.5.3 PV system monitoring.....	<del>46</del> <del>44</del>
4.1.5.4 Additional system components .....	<del>48</del> <del>46</del>
4.1.5.5 Dismantling PV systems at the end of life.....	<del>50</del> <del>48</del>
4.1.5.6 Summary of improvement options and impact on Performance, Bill of Material and product price .....	<del>50</del> <del>48</del>
4.1.6 BIPV module and system .....	<del>52</del> <del>50</del>
4.1.6.1 Standard product scope: performance.....	<del>52</del> <del>50</del>

Field CodeChanged

4.1.6.2 Extended product scope: energy generation potential and reliability (incl. warranty/product claims) .....	<del>54</del> <u>51</u>
4.2 Lifecycle analysis available data sources to model production for lifecycle analysis <del>55</del> <u>53</u>	
4.2.1 Selected data sources and BOM .....	<del>55</del> <u>53</u>
4.2.1.1 Modules – .....	<del>55</del> <u>53</u>
4.2.1.2 Inverters .....	<del>56</del> <u>54</u>
4.2.1.3 System level .....	<del>57</del> <u>54</u>
4.3 Conclusions and recommendations .....	<del>58</del> <u>56</u>
4.3.1 Module design options .....	<del>59</del> <u>56</u>
4.3.2 Inverter design options .....	<del>60</del> <u>57</u>
4.3.3 Photovoltaic system design options .....	<del>61</del> <u>58</u>
References .....	<del>63</del> <u>60</u>
List of abbreviations .....	<del>69</del> <u>66</u>
List of figures .....	<del>70</del> <u>67</u>
List of tables .....	<del>71</del> <u>68</u>
Annexes .....	<del>72</del> <u>69</u>
Annex 1. Title of annex .....	<del>72</del> <u>69</u>

## 4. Task 4: Technical analysis including end-of-life

### 4.0 General introduction

To allow policymakers, which often do not have a technical background, to understand the processes involved in the functional performance of the products, a brief and simple technological description of the products is made in this task. This technological analysis is conducted for technologies that are already on the market and that will become the basis for the base cases, but also for the identification of the Best Available Technologies (BAT) and state-of-the-art of the Best Not-yet Available Technologies (BNAT). This analysis concerns the product level, the component level and improvement potentials.

The aim of this task is also to collect a comprehensive data set of whole life data to undertake the analysis of the life cycle environmental impact and economics in the following tasks of this preparatory study.

Taking assumptions and life time definitions from Tasks 2 and 3 as a starting point, the following sections include an examination of factors that influence the technical lifetime of standard and potential BAT products, their performance, costs, end of life treatments, etc.. It focuses on the following main aspects:

- Performance
- Reliability and durability of product design
- Product end of life and circularity routes
- Resource use and hazardous substances

### 4.1 Technical product description of PV module, inverter and system solutions

#### Aim and background:

In this task a comprehensive technical analysis of the performance and design options of the products present in the market will be carried out.

There is an array of different photovoltaic module technologies, which have been the subject of intense research and development for the past decades, as it is depicted in Figure 1, where the evolution of record module efficiencies can be seen.



The MEERP guidance also notes that:

- BNAT technologies could be accelerated to market by incentive programs once they have been evaluated as such in the Ecodesign preparatory study.
- the BNAT-level can be an indicator for future new energy classes i.e. A class must remain empty for BNAT.

#### 4.1.1 Crystalline silicon PV wafer and cells technologies

##### 4.1.1.1 Strict product scope of PV wafer technologies: performance

###### 4.1.1.1.1 Wafer preparation

The complete value chain of silicon-based photovoltaic modules starts with the production of individual silicon wafers[1]. These individual silicon wafers are then processed into individual silicon solar cells, which are assembled together into modules typically consisting of 60 or 72 solar cells. The first step to produce a silicon PV module is therefore to produce a wafer, which is a silicon substrate of very high electronic material quality that has a typical thickness of around 180 micro-meter and a typical surface area of 15.6x15.6 cm<sup>2</sup>.

Silicon wafer-based PV technologies have dominated the PV market since the beginning with a market share of around 95% of the global PV module production in 2017 [2]. Silicon wafer production is a long and energy-intensive sequence [3].

Metallurgical-grade silicon (MG-Si) requires high purity silicon in the form of quartz. There are various definitions of High Purity Quartz (HPQ) relative to the total and elemental contamination. The ultimate purity of the silica depending on the extent of which contaminants such as aluminium, titanium and lithium can be removed. Naturally-occurring ultra-pure SiO<sub>2</sub> (greater than 99.997%) which is suitable for production of high-purity fillers, silicon metal and use in solar cells and semi-conductors is geologically rare and commands a significant premium over the price of lower grader material<sup>1</sup>.

At first, silica is reduced in an arc furnace to produce metallurgical-grade silicon (MG-Si), which contains high levels of impurities. Thus, MG-Si is dissolved in hydrogen chloride and the resulting chlorosilanes are distilled to produce high-purity silane gas, most commonly trichlorosilane (TCS). TCS is used in the Siemens process to produce polysilicon rods, which are broken into chunks and used as feedstock for the subsequent ingot production processes. Fluidized bed reactor (FBR) technology, as an alternative to the Siemens process, ~~did previously receive is gaining traction~~attention, owing to its lower energy usage [4], ~~but it has now fallen out of favor~~.

For the sawing of the wafers, Diamond Wafer Sawing (DWS) is an alternative to slurry-based wafering (which still represents 50% of the market for multi-Si). It reduces kerf loss by 30%, and so directly reduces material and energy consumption<sup>2</sup>.

##### Multi-crystalline Silicon wafer preparation

Two main types of ingot growth techniques are used for PV wafers, namely direct solidification (DS) and the Czochralski (Cz) process. Direct solidification is a casting method whereby polysilicon feedstock is melted and solidified in a large crucible to produce a large multi-crystalline silicon (mc-Si) ingot. Today's typical Gen 6 multi-c ingot is produced using 800 kg silicon charge and can be cut into 6x6 bricks [5]. The bricks are eventually sawed into individual wafers. During the sawing process, a significant amount of silicon is lost, which comprises the kerf loss. Typically thickness of mc-Si wafers today

<sup>1</sup> <http://www.verdantminerals.com.au/projects/dingo-hole-silica-project-nt/silica-high-purity-quartz-information>

<sup>2</sup> [International Technology Roadmap for Photovoltaic, ITRPV, 2017: http://www.itrpv.net/cm4all/uproc.php/0/ITRPV%20Ninth%20Edition%202018\\_1.pdf?cdp=a&\\_id=16224ec6558](http://www.itrpv.net/cm4all/uproc.php/0/ITRPV%20Ninth%20Edition%202018_1.pdf?cdp=a&_id=16224ec6558)

Formatted: Font: Not Bold

Formatted: Subscript

Formatted: Left, Indent: Left: 0 cm  
Hanging: 0.25 cm

Formatted: Font: 7.5 pt

is  $\sim 180 \mu\text{m}$ . P-type mc-Si wafers constitute about 62% of the market share in 2017 [6]. Mc-Si wafers contain different crystallographic silicon grain orientations and hence grain boundaries which will limit the resulting energy conversion efficiency of solar cells made from this material.

Given the inferior quality of mc-Si compared to mono-crystalline, owing to the large number of structural defects, grain boundaries and impurities, various efforts to improve the electrical quality of mc-Si wafers have been undertaken. High-performance (HP) mc-Si wafers, which have a more uniform distribution of smaller grains and lower dislocation cluster density compared to traditional mc-Si wafers, exhibit higher bulk minority carrier lifetime and have been a huge success in recent years [5]–[7]. As such, the 2017 market share for HP mc-Si is around 40% compared to 20% for traditional mc-Si [6]. The market share of the highest quality of mc-Si referred to as mono-like Si wafers, which consist of large grains (predominantly (100) grains) is negligible today, and is ~~but not~~ is expected to increase in the coming years.

### **Mono-crystalline wafer preparation**

In the Cz process, a single crystal of silicon (without any grain boundaries) is pulled out of a polysilicon melt using a small seed crystal to form a large cylindrical boule of mono-crystalline silicon with a typical body diameter of around 205–215 mm. The boule is then cropped and squared before being sawed into individual wafers. The off-cuts of the ingot are recycled by adding them back to the melt. Typical thickness of mono-Si wafers is  $\sim 180 \mu\text{m}$ , which is expected to decrease faster than mc-Si wafer thickness, in the coming years. Wafer sizes are expected to gradually increase from M0 (200mm diameter with 156.0mm side length) ~~M1 (diameter for 8.2-inch silicon wafer is 205 mm, and edge distance is 156.75 mm)~~ to M2 (diameter for 8.2-inch silicon wafer is 210 mm, and edge length is increased by 0.75 mm to 156.75 mm) which on module level can lead to more efficient area usage. Today the M2 format is the standard, in addition to M4 (211mm diameter with 161.7mm side length). Mono-c Si wafers take up about 38% of the market share and are mainly dominated by p-type Si, with only about 4% attributed to n-type Si for higher efficiency [6].

### **Alternative to traditional wafer preparation: kerfless wafers**

Since silicon is an expensive material, accounting for  $\sim 40\%$  of the costs at module level, **there is a strong drive to reduce wafer thickness and kerf** (due to the sawing) **silicon material losses**. With the present wafering technologies and the PV value chain described above, it is challenging to achieve sub- $100 \mu\text{m}$  silicon wafer thickness<sup>3</sup> and to eliminate kerf loss. To this end, a wide variety of alternative and disruptive technologies have been under development. The set of technologies that produce silicon wafers or foils ( $< 70 \mu\text{m}$ ) with negligible or no kerf at all is collectively called kerfless or kerf-free wafering techniques, most of which rely on the detachment of thin Si active layers from the top of a substrate or ingot, a process that is termed lift-off.

Two of the lift-off techniques that are currently at advanced stages of development and that are being considered for commercialisation are (1) stress-induced lift-off, and (2) porous silicon-based lift-off of epitaxially-grown silicon. Stress-induced lift-off involves stress-induced spalling of thin layers of silicon from the surface of an ingot or a thick substrate using a stressor layer and a thermal cycle, without kerf loss. Until recently Silectra has been involved in the development of this technology, aspiring to its potential commercialization. Though, in view of Silectra's recent acquisition by Infineon Technologies, it is yet to be verified – to our knowledge – whether there is any mid-term (BNAT) feasibility on commercialization of cold split for PV Si Wafers. ~~The company Silectra is still actively involved in the commercialisation of this technology~~ [8]. Porous

<sup>3</sup> The challenge is not so much to produce thin wafers, but to handle them and not to lose efficiency in the cell as there is less material to absorb the light.



silicon-based lift-off of epitaxial Si is another disruptive technology which not only tries to reduce or eliminate kerf loss but also to short-cut the extensive PV value chain by getting rid of the Siemens process as well as the ingot growth processes (casting or Cz pulling) [9]. This technology is currently being commercialised by NexWafe [10]. The parent substrate is re-used several times to produce an epitaxial wafer per cycle.

#### 4.1.1.1.2. Silicon material

Formatted: Font: Not Bold

##### **Silicon recycling in wafer production**

Silicon material that is recycled from the silicon kerf losses during production, or from end-of-life PV modules, or from yield losses during cell and module processing (broken wafers), can be re-used after purification in the ingot production of either multi-crystalline or mono-crystalline silicon. In this way, new ingots can be grown that consist partially of recycled silicon and partially of "new" silicon. This research topic is under investigation and its impact on cell performance and reliability is difficult to predict.

##### **Silicon recycling from the end of life of PV modules, methods and value**

Recycling of silicon at the end of life is in theory possible and several patents and methods are known [11][12]. Nevertheless, today Silicon recycling is not done because it isn't economically viable [13]; the rationale for this is the low value of Metallurgical Grade Silicon (MG-Si), which was about 0,8 €/kg (2015). This price is relatively stable as MG-Si is mostly used in the ferro-industry and is dominated (about 40 %) by the cost of electricity for manufacturing [14]. The market value of ultra-pure photovoltaic grade polysilicon was in 2015 around 18 €/kg [13] but today (10/2018) the price even dropped below 10 €/kg<sup>4</sup>.

-As shown in the literature, the silicon metal recycled from PV module waste could likely only replace metallurgical grade silicon at the stage before the production of solar grade polysilicon, i.e. the conversion of metallurgical grade silicon into hyper pure polysilicon which is the feedstock for solar wafers. Hyper pure polysilicon from quartzite would still be required and cannot be fully substituted by recycled silicon. This is because of the dopants and impurities that are likely to be present in a PV module silicon waste stream. As a consequence, the silicon scrap value in a module has to be compared at its best with metallurgical grade silicon ( $\approx 1$  euro/kg), which is relatively cheap in comparison with solar grade polysilicon ( $\approx 15$  euro/kg).

Silicon recycling therefore will likely not have a significant impact on reducing the need for crucibles in the polysilicon purification process, which relies on consumption of ultra-pure quartz (SiO<sub>2</sub>) mineral. More information on module recycling is in section 4.1.1.2 and 4.2.

##### **Silicon metal or ultrapure quartz mineral for crucibles as a Critical Raw Material**

Despite that silicon is next to oxygen the most abundant atom present on earth [15], 'silicon metal' itself was considered as critical raw material for a circular economy [16]. Therefore it is discussed in more detail in this section. Given that silicon metal is available in large quantities for use in steel and aluminium alloys [15]; it is not obvious to consider this a critical raw material (CRM). However, note that the U.S. Geological Survey (USGS) does not survey the ultra-high-purity silicon industry for production and related data as they have only information in their report about these grades from foreign trade statistics and published sources [15].

As was noted in Task 1, silicon metal has now been identified in Europe as CRM. Little information is disclosed on the rationale to consider silicon metal as CRM, it only refers to the fact that it is the base from which the ultra-pure Silicon used for photovoltaic cell

<sup>4</sup> [Dago announces 6.8\\$/kg cots in 2020, Siemens technology. https://www.pv-tech.org/news/dago-targeting-polysilicon-production-costs-of-us6.80-per-kilogram-in-2020](https://www.pv-tech.org/news/dago-targeting-polysilicon-production-costs-of-us6.80-per-kilogram-in-2020)

manufacturing is ultimately derived. Quartz ( $\text{SiO}_2$ ) with a low level of impurities is a good starting point for PV manufacturing and mining today is focused at these resources. Looking into more detail in the previous described manufacturing steps, another potential more critical issue is the dependency or resource depletion of ultra-pure silicon used for crucibles [17], they are needed in the purification processes described before. So far, little information is given or disclosed by manufacturers on this resource consumption and origin of their materials [18]. As a conclusion, the mining capacity and consumption of ultrapure quartz mineral<sup>5</sup> to manufacture could be considered as critical.

#### **4.1.1.2 Strict product scope of PV cell technologies: performance**

The next step in the silicon PV value chain is to process individual silicon wafers into individual solar cells. Whereas the silicon wafers are just substrates, the silicon solar cells are working electronic devices that contain a p-n junction, metal contacts, surface passivation layers and an anti-reflection coating. In the last decades a large variety of crystalline silicon (c-Si) solar cell concepts have been developed by universities, R&D institutes, and manufacturing companies with the primary goal to improve energy conversion efficiency without significantly increasing processing costs. The following paragraphs give a brief overview of standard single-junction c-Si solar cell concepts most relevant to industry.

##### **Aluminium back-surface field (Al-BSF) technology**

The vast majority (~90%) of c-Si solar cells manufactured today are based on two-sides contacted solar cells [6]. Among these cells, the so-called aluminium back-surface field (Al-BSF) technology has been the dominant technology due to its simple cell design and relatively good resulting cell performance. Best reported large area (244.3 cm<sup>2</sup>) **Al-BSF energy conversion** results on monocrystalline c-Si are around **20.8%**. Al-BSF solar cells are limited by two main loss mechanisms occurring at the blanket rear Al contact: (1) recombination of photo-generated charge carriers, (2) parasitic absorption of infrared light.

##### **Passivated emitter and (totally diffused) rear cell (PERC/T) technology**

To overcome these loss limitations from recombination and infrared absorption, the so-called "**passivated emitter and rear cell**" (**PERC**) was introduced in 1989 by UNSW but it took until 2014 for manufacturers to start adding significant production capacity of industrial PERC cells [19], [20]. The key feature of PERC concepts is that the rear side is passivated by dielectrics, typically a stack of  $\text{Al}_2\text{O}_3/\text{SiNx}$ , and subsequently patterned to form local contacts. Today's best manufacturers are reporting **average PERC efficiencies** in production of around **22.0%**.

An alternative high-efficiency concept to PERC is the so-called "passivated emitter, rear totally diffused" (PERT) concept. In this concept, the rear side is totally diffused prior to dielectric passivation and subsequent metallization. The main benefit of PERT concepts is that lateral resistive losses to the rear side local contacts are reduced which relaxes bulk conductivity requirements. PERT concepts are being evaluated on both p-type and n-type c-Si. However, a major limitation of PERT is the extra processing complexity versus PERC. For this reason, research is on-going in PERT concepts to either simplify the junction formation sequence and/or the metallization sequence. In both PERC and PERT concepts, recombination losses are significant, particularly at the metal contacts, which limit the achievable open-circuit voltages ( $V_{oc}$ ).

##### **Silicon heterojunction**

Silicon heterojunction (SHJ) cells overcome this issue (typical  $V_{oc}$  values are 730-750 mV) by making use of a thin stack of intrinsic and doped hydrogenated amorphous (a-

<sup>5</sup> <https://www.sibelco.com/markets/renewable-energy/>

Si:H) to simultaneously passivate the c-Si surface and extraction for photo-generated carriers [21]. For two-side contacted SHJ, record efficiencies up to 25.1% have been demonstrated on large area n-type Cz and equipment manufacturers are now demonstrating **average efficiencies above 23%** in pilot-production.

### **Back-contact cell technologies**

Compared to two-sides contacted solar cells, back-contact solar cells have both contact polarities on the rear side which significantly reduces optical losses at the illuminated front side both from cell metallization and cell-to-cell interconnection. Various back-contact cell designs have been developed with the main ones being interdigitated back contact (IBC), metal wrap through (MWT), and emitter wrapthrough (EWT) [22]. In IBC solar cells, all metallization grids are placed at the rear side which completely eliminates front side shading losses and improves aesthetics. Current commercially available IBC based modules manufactured by Sunpower achieved an efficiency of 24%.

The benefits of IBC solar cells (no shading losses, improved aesthetics) and SHJ solar cells (excellent Voc) can be combined in so-called **IBC-SHJ which has culminated into the world-record 26.7% efficiency for c-Si solar cells set by Kaneka** [21]. Further process simplifications are however required to commercialize IBC-SHJ cells. First success in simplification has been recently reported by Meyer Burger with cells reaching 25% efficiency from industrial process flow. Due to the temperature sensitivity of amorphous silicon, an interesting alternative is to use doped polysilicon layers for contact passivation [23].

### **Bifacial technologies**

Finally, a promising approach to further improve the performance of c-Si solar cells is to make solar cells bifacial so that both sides capture incident and diffuse sunlight [24]. **Most high-efficiency cell concepts such as PERC, PERT, SHJ, IBC, IBC-SHJ can be made bifacial** simply by using metallization grids at the rear side instead of blanket metal layers. This enables the reduction of the cell metallization and simultaneously increases the cell and module performance. Integration of these cells into PV module requires either glass-glass packaging or the use of transparent backsheets at the rear.

An overview of various cells architectures is displayed in **Error! Reference source not found.**

Formatted: Indent: Left: 0 cm

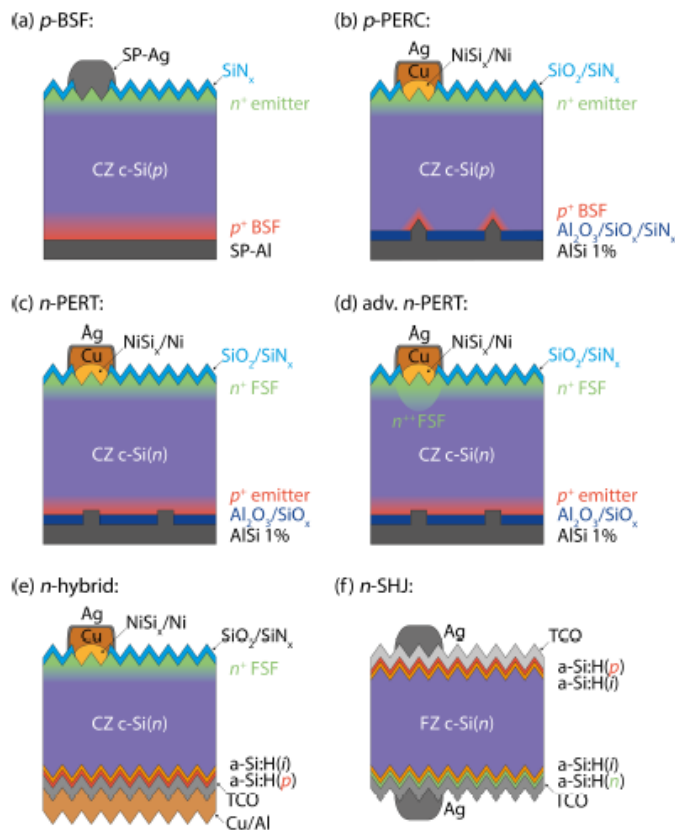

Figure 24: Overview of various cells architectures: (a) Al-BSF, (b) PERC, (c,d) PERT, (e) SHJ, (f) bifacial SHJ [25]

## 4.1.2 Crystalline silicon module technologies and materials

### 4.1.2.1 Crystalline silicon module technologies and materials

#### 4.1.2.2 Strict product scope

The term photovoltaic (PV) module refers to an assembly of typically 6x10 or 6x12 series-connected solar cells, packaged into a protective multi-layered structure, which comprises 5 main components (Figure 3Figure-2): a front cover (tempered glass), the electrical circuit (the interconnected solar cells matrix) in an envelope of two encapsulant layers (front/back) and a back cover (backsheet or tempered glass). Externally, metal frames consisting of racking components, and brackets are used to better support the panel+module structure.

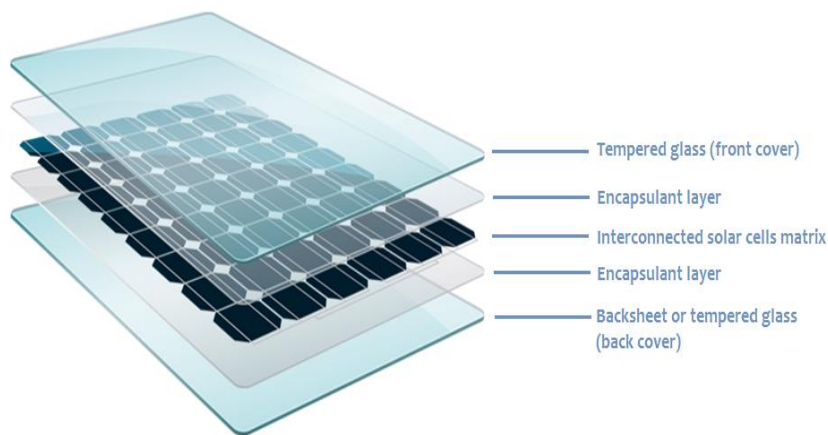

Figure 32: Typical structural layers in a c-Si PV module

Each module is rated by its DC power output under standard test conditions (STC), which – for standard applications - typically ranges from 200 up to 435 W; while typical electrical efficiencies of commercially available PV modules are found in the 16-22% range. Electrical cables (i.e. positive and negative terminals), linked to a so-called junction box (situated on the back side of each PV module), are used to connect multiple modules either in series or in parallel to achieve respectively higher voltage or current outputs, at a PV system level.

PV modules are intended to operate outdoors – thus, being exposed to diverse field (environmental) conditions – for operational lifetimes that often exceed 20 or 25 years. Therefore, superior performance and long-term reliability are pivotal drivers of R&D in materials and technology for PV modules and components (i.e. interconnections, backsheet, encapsulant and glass).

The following section deals in turn with interconnections, the backsheet, encapsulant, front glass, the junction box and bypass diode. For some of these components the possibility of repair/replacement is discussed depending on their significance according to potential performance losses. As can be seen in [Figure 4](#)[Figure-3](#), the cost of module repair is in general relatively high when compared with the output losses. The reason may lie in the fact that the substitution of the defective module is the preferred procedure

to repair, because the action of repairing modules could void the module manufacturer's warranty, but comes at a higher cost.

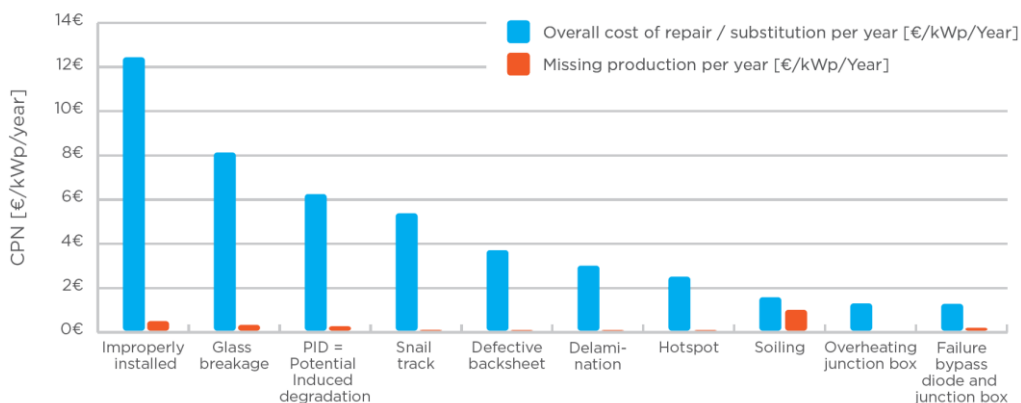

Figure 43. Costs during operation and maintenance (CPN), repair costs ( $CPN_{\text{repair,fo}}$ ) and performance losses ( $CPN_{\text{never,detected}}$ ) for top 10 risks for PV modules of all system sizes. Source: Solar bankability, 2017

## Interconnection

Today, the most common PV module fabrication technology involves stringing of 2-side-contacted photovoltaic cells. The generated electrical current is collected through distributed metal fingers across the cell into typically two or more busbars. **By soldering tin lead ( $\text{Sn}_{62}\text{Pb}_{36}\text{Ag}_2$ ) coated copper ribbons to these busbars, cells are electrically connected** in series to form cell strings. The exact silver content can change however the remaining composition of the alloy is little altered to remain close that eutectic formulation required for reliability. The size of these ribbons is a compromise between shadowing on the illuminated surface of the cells and resistive losses. The individual cell strings are connected with string connection ribbons and laminated into a module. The exact size of the ribbons is adapted by the manufacturer for every module product.

Soldering ribbons can be applied through different processes: hot bar, laser, hot air, infrared and induction. During the process the solder alloy temperature must be raised above the melting temperature of the solder alloy ( $>185^\circ\text{C}$ ) to create a solder joint between the cell and ribbons. This is implemented through gradual heating stages in industrial tabber and stringers to minimise thermal stress on the cell and improve the production yield.

For both improving electrical performance and reducing optical losses, a trend towards an **increasing amount of busbars** is materializing [26]. Indeed, for the same amount of material, a lower resistive loss can be obtained by decreasing the finger losses or alternatively for the same loss, **less material is needed**. In terms of optics, more narrow ribbons will result in a reduced reflection out of the module and thus enhance sunlight recovery, yielding a higher current.

Increasing the number of busbars on the cell and interconnection ribbons on the module overall leads to slight increase of the solder use, and hence the Pb content of PV module. We estimate the change from 2 busbar cells to 5 busbar cells leads to  $\sim 5\text{-}10\%$  increase in the volume of Pb/module.

Culminating this trend are **multi-wire interconnection technologies**, with the additional advantage that busbars are no longer needed on the cells and the conductivity of the fingers can be strongly reduced, decreasing the cost of the silver metallisation on cell level. Apart from the electrical and optical benefits, also the aesthetics are improved, yielding a darker (cf. reduced optical losses) and more uniform module surface.

Two such **multi-wire interconnection technologies** are introduced on the market. One approach effectively mimics the standard technology by soldering SnPbAg coated

**Formatted:** SpaceBefore: 6 pt, A after: 6 pt, A djustspace betwen Latin and A siantext, A djustspace betwenA siantext and numbers

ribbons on finger solder pads, replacing the busbar[27]. High performance and reliability have been demonstrated with this approach and is already in volume production by LG [28], reaching 340 Wp and 20% efficiency. A second approach applies a contact foil directly onto the metallized cell followed by a lamination process; this is the so-called Smart Wire Connection Technology (SWCT) [29]. The contact foil integrates low-temperature-solder-coated copper wires (with In or In-free formulations) on an optically transparent supporting film (PET) with an adhesive layer. The exact solder coating formulation and process to apply the solder coating is currently little known.

Next to multi-wire, **electro-conductive backsheets** have entered the market as a busbar-less cell interconnection option for standard BSF and future cell types. Amongst others, Sunport Power currently has a production capacity of 1GW in China, Energyra starting a 150MW line in NL and Silfab 300MW in the US. Due to full back-contacting of cells and reduced resistive losses, the cell-to-module (CTM) loss is eliminated. To enable back-contacting of cells, the front-side metalization is guided through holes (vias) in the cell to the backside (Metal Wrap Through technology). For IBC cells this is not needed as both contacts are already positioned at the back-side.

Formatted: Font: Bold

### **Lead-free soldering and ECAs**

**Low temperature and lead-free solder alloys** have the following compositions:  $\text{In}_{(52-42)}\text{Sn}_{(52-42)}\text{Ag}_{(0-2)}$  or  $\text{Sn}_{(50-60)}\text{Bi}_{(38-48)}\text{Ag}_{(0-2)}$  with melting temperatures of 118-145°C and 139°C, respectively. During the lamination the wires of the contact foil are soldered directly to the metal fingers of the cell. In their latest version, Meyer Burger has demonstrated 60-cell modules with HJT cells reaching 335 Wp, based on In-free soldering and UV-transparent encapsulation (white tiger foils) [30]. They also publish good reliability results up to 2-3x IEC testing for damp heat and thermal cycling, for both glass-glass and glass-backsheet modules. Although their commercialization is reportedly could be gradually starting up [RECnews], the 10<sup>th</sup> edition of the ITRPV (2019) only shows a very limited uptake of lead-free soldering in 2018/19 (~10%) and forecasts that share only to grow to 25% by 2025-

Formatted: Superscript

Similar low-temperature solder coatings can be also used in combination with standard ribbon interconnection technologies relying on tabber and stringer for the soldering. Implementation of Pb-free soldering for the interconnection of various types of solder cells is under investigation by numerous players. Although, Meyer Burger and several other players reported that their Pb-free technology can pass IEC certification proving the reliability of solder joints, the material and process development required to reach these targets is challenging. The low temperature solder alloy intrinsically have higher diffusivity and form brittle intermetallic alloys [31]. Their low solder temperature compared to SnPbAg can also mean that they will not meet the requirements of certain high temperature applications of PV modules (e.g. BIPV).

*In short, our current insights on low temperature and lead-free solder alloys is limited and their potential to reach extended PV module lifetime (and which conditions) up to 25-30 years has to be further proven.* The use of Sn or its alloys: Sn(Ag, Cu, Zn) with melting temperature above >200°C is difficult to combine with current PV cell types and PV module assembly processes. The trends to evolve to more advanced cell structures (with high temperature sensitivity) and/or thinner wafers will make the integration of Sn based alloys in the module process even more difficult.

More challenging solar cell processing due to thinner wafers and emerging new cell designs that cannot resist to high T process have raised the need for an evolution in electrical interconnect materials [32]. The use of **electrical conductive adhesives (ECA)** in heterojunction and certain thin-film technologies is implemented for ribbon soldering. Furthermore the emerging shingled PV modules and back-contact cells connected with conductive backsheet interconnect technology often rely on ECAs. Conductive adhesives are generally based on a polymeric matrix, which is filled with

conductive metal particle (Ag most commonly). During manufacture, storage and processing the adhesives are liquid and can be applied with appropriate dispensing systems or printing technique. A thermal (or in some cases UV cure) step is indispensable to ensure good glueing and electrical conduction. The temperature treatment remains < 150°C in most cases hence considerably lower the soldering process temperature.

This interconnection section describes the solutions for two-side contacted (mono- and bifacial modules). For back-contact cells a number of different approaches exist which are often developed jointly with the cells technology. A detailed review of the technologies and materials is available here [33].

### Backsheet

The PV backsheet is designed both to perform as an electrical insulator and to protect the inner "active" components (i.e. solar cells and interconnections) from external stresses including UV radiation, daily and seasonal thermal cycles, operating temperatures up to 90°C or higher, as well as mechanical loads (due to snow and wind). PV backsheets typically follow a three-layer structure, comprising a core layer and two protective layers. Most core layers are based on polyester (i.e. PET) which alone offers a suitable and cost-efficient solution for electrical insulation and against moisture ingress. The core layer is sandwiched with the two protective layers (on the cell and air side respectively) which mainly protect the core from UV induced degradation and hydrolytic degradation.

On the basis of the material used in the latter ~~s~~, module **backsheets** can be classified in two groups; **fluoropolymers and non-fluoropolymers**. For products from the former group, either one or both of the protective layers are fluorine based; made up either by polyvinylidene fluoride i.e. PVF (Tedlar® [34]) or by polyvinylidene difluoride, i.e. PVDF (Kynar® [35]). In a different approach [36], a so-called fluorine skin is used facing to the cell side of the backsheet and Kynar/PVDF film for the air side, thus providing sufficient UV protection, while avoiding the use of expensive fluoropolymer films on the cell side. On other hand, fluorine coating based alternatives [37], [38] are suggesting significant cost-efficiency, due to 50% lower consumption of fluorine, and reliability scores similar to the fluoropolymer film based products.

In the non-fluoropolymer segment, technological advances in polyester chemistry and film production engineering have enabled the development and commercialization of PET or polyethylene-based films [39], [40] or coatings [41] with enhanced UV stability, claimed with comparable protective attributes as fluoropolymer-based products [42]. Compared to fluoropolymer based products, backsheets with PET or polyethylene protective layers **come with about 20 to 30% lower price, however their long-term reliability in the field is not yet proven somewhat still in question**, with mixed opinions, particularly in terms of UV stability and adhesion quality under harsh environmental conditions.

~~Standing out~~ Apart from the above classification, ~~a rather atypical backsheet~~ another alternative [43] is a co-extruded backsheet. It recently introduced that employs a polyolefin (PO) film based core layer, with polyamide and polyethylene as protective layers at the air and cell side respectively. Material-wise, such solution may appear a "premium" and rather costly product. However, the co-extrusion technology, results in a faster lamination process, reduction in acetic acid as well as in mitigating potential induced degradation<sup>6</sup>. Instead of laminating pre-manufactured films with adhesives, these backsheets are produced in a single pass. This eliminates the need for pre-manufacturing of films, as well as solvent based adhesives. Furthermore, the thermoplastic character of the co-extruded backsheets makes them 100% recyclable and

<sup>6</sup> Kempe, M. Encapsulant materials for PV modules, chapter 10.2 in "Photovoltaic Solar Energy", Reinders et al. Wiley (2017)



the polyolefin based core layer is more durable, having greater hydrolytic stability and crack resistance compared to the PET films used today. The more durable core layer also allows for elimination of the use of fluoropolymers in the outer layers. Today about 10 companies supply/develop co-extruded backsheets, all PO core layer based<sup>7</sup>.

significantly lower manufacturing process costs and advantageous lifetime reliability similar to fluoropolymers, though without the use of fluorine and eventually priced lower by nearly 50% compared to typical Tedlar-based products.

Focusing then on certain application-driven features transparent [38] and colored backsheets can offer an advantageous lightweight alternative for bifacial PV and BIPV applications respectively, compared to today's prominent though heavy glass-glass PV module designs. Moreover, backsheets with highly reflective layers [44] - towards improved light management - are being developed. **Error! Reference source not found.** shows the different PV backsheet configurations available today.

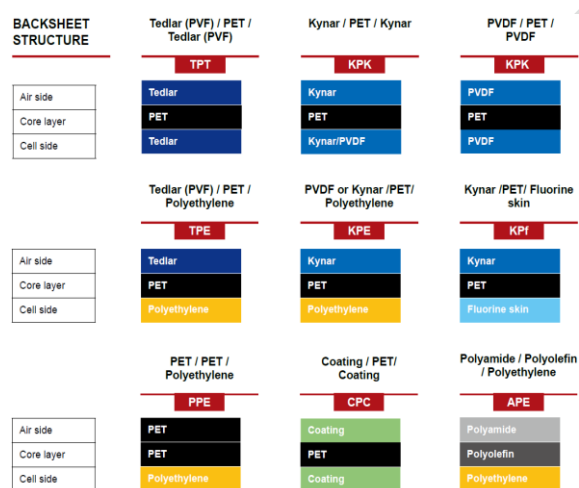

Figure 54: The different PV backsheet configurations available today. (Source: S.K. Chunduri and M. Schmela, "Market Survey on Solar Backsheets 2018", Public Report TaiyangNews@TaiyangNews-2017)

Formatted: Superscript

## Encapsulants

Next to PV backsheets, encapsulants play an equally significant role in preventing water ingress and/or dirt infiltration into the PV module structure, serving thus as an indispensable sealing layer for the solar cells. In addition, encapsulant layers on either side of the solar cell matrix, also act as shock- and vibration-protective shields. As such, in order to optimize PV module's performance and reliability, PV encapsulants should carry certain properties:

- Low light absorption and excellent transmission in the relevant spectral band (350–1200nm for c-Si technology), along with an adapted refractive index to minimize interface reflectance;
- High thermal conductivity, to minimize the operating temperature of the module, thus increasing its energy yield;
- Electrical insulation, against unacceptably high leakage currents;
- Durability against real-field environmental stressors, i.e. UV irradiation, humidity, thermal cycling, mechanical loads;
- Strong and uniform adhesive bonding towards the other module components;

<sup>7</sup> <http://taiyangnews.info/reports/market-survey-on-solar-backsheets-2018/>

- Cost-efficiency in terms of material, manufacturability and processing.

Selecting the appropriate encapsulating material is an important aspect in PV module design. In principle, encapsulant types be classified into two categories<sup>8</sup> [45]: i) non cross-linking thermoplastics or thermoplastic elastomers (TPE) and ii) elastomeric (forming covalent bonds between the polymer chains). Ethylene vinyl acetate (EVA) and two-component silicone and urethane (TPU) materials must be subjected to a crosslinking process which can be induced by high temperature levels or UV irradiation or via a chemical reaction.

Thermoplastic elastomers (TPE), polyvinyl butyral (PVB), thermoplastic silicone elastomers (TPSE) and ionomers, as well as modified polyolefines (PO), melt during the module manufacturing process without forming chemical bonds between the polymer chains (cross-linking). EVA particularly has been the exclusive PV encapsulant material for nearly 3 decades, thus being widely field-proven – with a solid record of long-term reliability – and a low-cost option as well. On the other hand, EVA's susceptibility to certain degradation mechanisms and the recent emergence of thin film and high efficiency solar cell technologies as well as new PV applications, has highlighted the need of introducing new PV encapsulant materials, e.g. the ionomers, the thermoplastics or the silicones.

Of the alternative encapsulants, TPSE are highly impermeable to water and have good UV resistance, light transmission and electrical insulation properties<sup>2</sup>. Besides, since the cross-linking is performed via hydrogen bonds, TPSE-based PV modules offer better recyclability compared to the EVA-based ones<sup>10</sup>. Moreover, thermoplastic PO (TPO) encapsulants are interesting candidates for PV modules, in terms of cost-efficiency, having also high electrical resistivity and resistance against hydrolysis; whereas, they also present no degradation related to acetic acid formation, which is a common degradation mechanism in EVA-based modules. However, compared to EVA, TPO presents significantly higher water permeation.

In thin film glass-glass and building integrated PV (BIPV) applications, PVB emerges as a competitive alternative to EVA, featuring superior UV stability and better adhesion to glass. Last but not least, ionomer-based encapsulants were also introduced as highly competitive alternatives to EVA, particularly in terms of rigidity and durability against mechanical stresses, reduced lamination cycle time, as well as high electrical resistivity and resistivity against moisture ingress<sup>11</sup>.

### Front glass

In the PV module packaging the glass is the third critical element, which both determines its performance, durability and safety. The front glass in PV modules is tempered low-iron containing extra clear glass of 3.2 mm in general. Recently the use of antireflective coating has become wide-spread. Anti-reflective glass can enhance the PV module performance by 2-3% as measured in standard testing conditions [46]. The durability of this treatment, especially in harsh environmental conditions is under validation. In most European climate the quality suppliers warrant 120 years of lifetime for this treatment.

An initial screening suggests that repellent properties are combined with Anti Reflective coatings. Chemistries which have been used as AR coatings are mostly based on silicon dioxide and may include zinc oxide and silicon-titanium dioxide. The latter two substances lend the coating, although it is not clear whether anti-soiling properties require additional more complex chemistries.

<sup>8</sup> C. Peike et al. (2013), "Overview of PV module encapsulation materials", Photovoltaics International.

<sup>9</sup> Wiesmayer et al. "Impact of Permeation Properties and Backsheet-Encapsulant Interactions on the Reliability of PV Modules, Renewable Energy 2012(1-4), DOI: 10.5402/2012/459731

<sup>10</sup> Peike et al. Overview of PV module encapsulation materials, Photovoltaics International Volume 19, 2013. <https://www.pv-tech.org/technical-papers/overview-of-pv-module-encapsulation-materials>

<sup>11</sup> Assessment of Photovoltaic Module Failures in the Field, Report IEA-PVPS T13-09:2017

Formatted: Font: 8 pt

Formatted: Indent: Left: 0 cm, First line: 0 cm

Anti-soiling and self-cleaning properties are under development and validation, they claim to improve the energy yield approx.1%/year. ~~however~~ However this strongly depends both on the local soiling rate and PV system installation. ~~The integration of this innovation is encouraged but not quantified in this study.~~ The weight of 1 m<sup>2</sup> front glass [47] with 3.2 mm thickness is 8 kg and therefore it contributes the most to the weight of a commercial module (>50 %). Further weight reduction is possible with front glass thicknesses up to 2.8 mm being available.

### Junction box and bypass diode

The junction box is an enclosure which contains and protects the cell strings of the PV module and their connection to the module's external terminals. Junction boxes are typically fixed on the backside of modules, using silicon adhesive. Inside a PV junction box, 4 connectors are wired together, comprising the output interface of the PV module; which, in turn, allows an easy and electrically safe connection of each PV module to the PV array, through cables with ~~MC4/MC5~~ electrical connectors (typically MC4/MC5). An important technical specification of PV junction boxes is the so-called IP (i.e. "Ingress Protection") rating as defined by the EN 60529. For instance, a completely water tight junction box carries IP 67. However, IP 65 is still a common rating among standard PV junction boxes.

The principle function of PV junction boxes is to ensure that the generated DC current flows at the correct direction. This function is carried out by one or more (typically three) bypass diodes, which indeed protect solar cells of each sub-module (cell string) from becoming reverse-biased and overheated (hot spots), when shadowing or other electrical mismatches occur. Schottky diodes is the most common type used as bypass diodes in PV modules. Such diodes are highly susceptible to static high voltage discharges and mechanical stress. Thus, careful treatment, avoiding any ungrounded contact should be ensured. Yet, under real-field conditions, i.e. throughout PV modules' operational lifetime, several bypass diode failures [48][49] may still occur as a result of single or combined factors (e.g. lightning strikes, repeated activation and thermo-mechanical stress cycles due to shading, etc), which eventually result in a module power output loss by at least one third (assuming 3 bypass diodes per module).

Bypass diode failures evolve and often go undetected, especially in the case of large-scale PV plants with inverter-level monitoring, as they relate neither to visible (physical) degradation nor to significant drop in the system's DC current and overall power. However, bypass diodes failures can be related to increased temperature, resulting in inhomogeneous that, in turn, can be easily and timely detected with the use of standard infrared (IR) imaging equipment. Moreover, with the recent advance of drone technology, aerial IR inspections are efficiently applied to PV plants to detect and identify modules with bypass failures that require repair and/or replacement (decommissioning)[50][51]. The repair or refurbishment of most modules affected by bypass diode failure is technically feasible, by simply dismantling them and replacing the failed diode in their junction box<sup>12</sup>. However, access to the diodes maybe prevented by the junction box sealing or casing design and some diodes are now soldered potentially preventing easy repairing/replacement.

An alternative solution to mitigate the aforementioned risks of electrical mismatches (e.g. due to shading) in a PV module, is also offered by recently introduced "smart" PV modules<sup>13</sup>; which come with built-in intelligent cell optimizers (Maxim integrated), at cell-string level, that minimize the power output losses and the risks of hot spot formation, without the need of bypass diodes. Yet, module-level monitoring is technically non-feasible in such cell string-level optimization, in contrast to the case of module DC optimizer or microinverters.

<sup>12</sup> <http://www.rinovasol.com/about.html>

<sup>13</sup> [https://jinkosolar.com/product\\_355.html](https://jinkosolar.com/product_355.html)

Other junction box failures that are commonly observed in the field may include poor fixing/adhesion on the PV backsheet, open or badly closed boxes due to manufacturing defects, moisture ingress with follow-up corrosion of the connections and internal arcing or short-circuit due to erroneous wiring. In general, a quality PV junction box is certified (e.g. via TÜV) for reliable long-term safety and sufficient heat dissipation in operating conditions.

#### **4.1.2.3 Extended product scope: energy generation potential and reliability under non Standard Test Conditions (STC)**

As mentioned, PV modules are rated (and sold) on the basis of their output power at STC ; besides, their electrical efficiency is often perceived as a conclusive indicator of their quality. However, from a PV installation and financing perspective, the energy produced in the course of a PV module's operational lifetime is a key determinant for the return of investment (ROI). As a result, PV stakeholders are shifting from a (rather misleading) module power-based rating, to a more accurate and specific rating based on the module's expected energy yield, commonly referred as "**energy rating**" of a PV module.

With an extended product scope, PV modules are rated, classified and optimally selected according to their site- or climate- specific energy yield. In this direction, the recent IEC 61853 series establish those requirements that are taken into account when evaluating PV module performance based on power (W), energy (Wh) and performance ratio (PR, %). Energy Yield and Performance ratio have also been discussed in detail in Task 3. In brief, PV module energy rating consists of 3 basic sets of data:

- module characteristics at STC, i.e. power, irradiance dependence, temperature coefficients and spectral response;
- reference weather data (at least irradiance and temperature) for specific climates and configurations (tilt, azimuth, etc.) (see Task 3) and
- output data from detailed energy simulation(s) for the rated module(s) (see Task 3).

The life time for modules is for the purpose of this study defined as the time a module is used until the requirements of the user to provide a minimum of 80% of the initial rated power output is not fulfilled due to a degradation in performance and/or a product failure (see Task 1 report).

Given the current knowledge and state-of-the-art, energy yield predictions and module energy rating come with considerable uncertainties and limitations [52]. The latter are typically related to the influence of module's reflection and thermal response; but, most importantly, to the impact of long-term reliability, i.e. to the evolution of different degradation mechanisms and failure modes in PV modules and their components.

A significant number of research groups aspire today to establish accurate lifetime energy yield predictions for PV modules operating in the field, by means of simulation models. In overall, the current state-of-art modelling approaches can be divided into three main classes: finite element (FEM)<sup>14</sup>, circuit-based and parametric modelling approaches. Table 1 below shows the strengths and the weaknesses of each class. Most tools for PV energy yield simulation are based on black box models, calibrated with semi-empirical parameters [53]–[59]. In principle, these tools still neglect the degradation of PV modules over time or, in the best case, assume steady-state losses (i.e. gradual or linear degradation), without any correlation to degradation rates or failure modes. Hence, the impact of different climate- and site- specific parameters (e.g. environmental

<sup>14</sup> Finite element modelling (FEM) is a numerical method for solving problems of engineering and mathematical physics. Thermal behaviour of modules is modelled considering

stressors) is neglected, due to time granularity and/or due to specific non-realistic assumptions, e.g. uniform module temperature. One example of a model is the one developed recently by IMEC, being based on bottom-up physics models [60]–[63].

Table 1. Comparison of different state-of-art approaches for PV energy yield modelling.

	<b>FEM modelling</b>	<b>Circuit-based</b>	<b>Parametric</b>
<i>Extrapolation</i>	+	-	--
<i>Temporal variations</i>	+/-	+	+
<i>Non-uniform irradiance</i>	+	+	-
<i>Fast</i>	-	+	++
<i>Versatile</i>	-	+/-	--
<i>Physics – based</i>	++	+/-	-
<i>Accurate</i>	++	+/-	+/-

However, if energy yield predictions and energy rating of PV modules are intended to give PV end-users (that are often non-experts) a clear and reliable indication of a PV module’s long-term performance, then they must also include thorough insights into the impact of lifetime reliability issues of PV modules. Through the years, research community and industry gained significant experience in understanding and minimizing reliability issues related to “infant mortality” of PV modules [64]. There are a number of opportunities to minimise failures during the production process related to :

- Incorrect cell soldering
- Undersize bypass diode
- Visually detected hotspots
- Incorrect flash test
- Arcing in a module

Rigorous and extensive “design qualification” and “type approval” tests exist to control quality, as per relevant established IEC, ASTM and UL standards [65]–[68]. However, the existing framework of qualification testing provides neither actual lifetime expectancy of a PV module nor any correlation to the influence of degradation and failures on its lifetime energy yield.

Over the last five years, active research [69]–[75] and collaborative programs [76]–[80] shed light on identifying the most commonly experienced degradation rates, reliability issues and dominant failure modes of PV modules: module optical degradation (delamination, encapsulant discoloration), packaging materials failure (fractured glass/frame, backsheet delamination and/or loss of adhesion, bypass diode and junction box failures), electrical mismatches (cell cracks, snail trails, broken interconnections) and electrochemical degradation (potential induced degradation (PID), corrosion).

Independent of the climatic and site conditions where a PV module operates, some failure modes stand out in terms of resulting power losses on module and/or system level. However, these failures are difficult to be properly assessed by PV operators and asset owners because there is still very little information on when, how often and how severely such reliability issues will occur in real-world PV installations, under combined stress factors (e.g. heat, moisture, UV radiation) and site constraints (e.g. shading, soiling).

“PVlife”, a reliability predictive tool developed by Mikofski et al. [81], [82], remains today at the forefront of PV reliability research, and claims to be able to determine long-term, temperature induced failures. However, it is adapted to PV modules that feature a particular type of commercial solar cells – the back contact products of US manufacturer

Sunpower, as reviewed in section 4.1.1.2 - which differ significantly from those in common PV modules. Besides, it is an entirely proprietary model, hence cannot be considered as accessible state-of-the-art.

#### 4.1.2.4 Recycling of PV modules

##### Market context

This section deals with the material content and possibilities to recycle crystalline PV modules in a circular economy perspective. End-of-life (EoL) management of PV modules in the EU Member States is regulated by the Waste Electric and Electronic Equipment Directive since its revision of 2012 (2012/19/EU). The transposition period for the different Member States concluded in February 2014 setting collection, reuse and recycling targets.

Collection, recycling and the financing of the future waste management is often coordinated by Producer Responsibility Organizations (PRO), such as PV CYCLE [83]. Small-quantity, household PV waste is collected by take-back infrastructures, being either certified collection points (such as in France and the UK) or municipality collection sites (such as partly in the Netherlands and Germany). For large quantities at professional sites or solar farms, tailor-made pick-ups can be arranged for on-site collection. CENELEC has developed a supplementary standard specific to PV ~~panel~~ module collection and treatment to assist treatment operators (EN\_50625-4).

According to International Energy Agency (IEA) and International Renewable Energy Agency (IRENA) by 2030, the projected waste PV modules will amount to 1.7 – 8 million tonnes and 60 – 80 million tonnes by 2050 as per in 2016 for the low and high scenarios of PV deployment figures by IEA. Moreover, the EU WEEE directive requires 85% ~~recovery rate by mass~~ of waste PV modules shall be recovered and 80% shall be prepared for re-use and recycled by mass [86]. Currently, the dedicated recycling of both crystalline-Si PV modules and non-~~Silicon~~ silicon modules is not feasible at a commercial scale with some limited exceptions. However, to improve the process efficiency, recovery and recycling rates, cost effectiveness, and environmental performance capabilities of these methods, several approaches have to be developed.

~~In the next 10-15 years, up to 80% of the PV module "waste" stream estimated by IRENA will consist of products with premature failures [84], such as production defects or damage from transportation and installation, instead of products reaching EoL. Based on broader information about failure rates, it can be~~ Therefore it has been estimated that about two thirds of these PV modules may be possible to repair or refurbish. ~~Therefore~~ Consequently, about 50% of the PV ~~module~~ Panel "waste" can be diverted from the recycling path. In reality, the ratio will be even higher since decommissioned functional PV modules currently also enter the "waste" stream. Approaches are proposed to develop a global end-of-life treatment for PV modules where modules are sorted (with automatic recognition) and diverted between refurbishment and recycling paths.

Nevertheless, re-use, repair and refurbish remain rather informal in the PV industry today. These activities are currently performed by independent private companies, without any support from the original manufacturers. There are currently limited regulations or standards on the testing, certification and labelling of refurbished PV modules. The repaired/refurbished PV ~~panel~~ modules are often rebranded and sold largely to less developed electrified markets. A small portion is sold on European markets via e.g. online second-hand platforms. Since it is still an informal sector operating at small-scale and geographically specific (e.g. Germany), almost no data is available. More information is already available in the Task 3 report. There are several ongoing research initiatives in the area of PV eco-design, such as CABRISS<sup>15</sup> and Eco-Solar<sup>16</sup>, aim at

<sup>15</sup> CABRISS is a joint initiative of 16 European companies and research institutes and received approval by the EU's Horizon 2020

reducing resource consumption in PV production, increasing material/value recovery in PV recycling, and using recycled raw materials in new PV **PanelModules**. The most advanced achievement regarding design-for-circularity so far is the NICE glass/glass module technology developed by APOLLON SOLAR<sup>17</sup>. The module has no encapsulation material, no soldering and no lamination requirement. Therefore components can be recovered for further recycling or re-use.

Within recycling operations the PV modules are separated by module technology (silicon-based or non-silicon based) and sent for recycling[13]. PV module collections from small installations (e.g. residential installations or households) can pose a significant challenge due to their mixed brands and technologies in small quantities.

### Recycling PV modules: technologies

Recycling technologies can be classified into bulk recycling (recovery of high mass fraction materials such as glass, aluminium and copper) or high-value recycling (recovery of both semi-conductor and trace metals)<sup>18</sup>.

Currently the most common approach in PV module recycling is a bulk recycling using a crushing and grinding process after the removal of the junction box and the frame. With this method over 90% of the cSi PV **panelmodules** by weight can be recycled[85][13]. A PV module is mostly glass and aluminium in weight and consists only a small amount of more valuable metals such as copper, silicon and silver. The market price of recycled glass cullets, often used for new glass products and glass insulation or glass foam applications, is at about €50 per ton at best and is subject to volatility. The raw materials (mainly glass cullet and scrap aluminum) recovered from PV module recycling amounts to less than €1 per **panelmodule**<sup>19</sup>. As a result, PV recycling is a net cost to the value chain and strongly relies on subsidy from Extended Producer Responsibility (EPR) schemes and directives. From crystalline PV modules the silicon itself is not recycled[13] with this approach for reasons mentioned in section 4.1.1.

Several alternative recycling approaches are under development that may allow for more sophisticated dismantling and segregation of the materials in a module. For example, the delamination of the glass from the cells has required the development of novel approaches to implement a high-value recycling. In the last few years, technology development and patents from different players are focused on the improvement of this step in particular<sup>20,21</sup>. After the removal of the junction box and framing, the delamination step using mechanical, thermal, chemical treatment and even more frequently a combination of them method are possible.

Optimized **thermal delamination** enables the intact recuperation of the Si wafer, which provides the highest value in recycling. However, this approach is expensive in low volumes and furthermore the incineration of fluorinated backsheet materials requires adequate safety measures.

Several **mechanical approaches** are investigated where either the cells are cut, scribing on the glass or non-glass is made, or a crushing/grinding process is applied. The first two approaches are more interesting where the low -Fe containing glass is kept intact and hence can be re-used in PV modules. Major disadvantage of the various mechanical approaches that recuperation of full wafer is currently not possible. It is important to mention that in combination with chemical processing, the recovery of metal and Si

<sup>16</sup> Eco-solar is a joint initiative of 10 European companies and research institutes and received approval by the EU's Horizon 2020

<sup>17</sup> N.I.C.E.™ (New Industrial Cell Encapsulation), from <https://www.apollonsolar.com/>

<sup>18</sup> P. Sinha, S. Raju, K. Drozdiak, A. Wade, Life cycle management and recycling of PV systems, PV Tech, 2017

<sup>19</sup> Based on market price of scrap glass and aluminum

<sup>20</sup> G. Heath et al, IEA End-of-Life Management of Photovoltaic Panels: Trends in PV Module Recycling Technologies, 2018

<sup>21</sup> K. Komoto et al., End-of-life management of photovoltaic panels: Trends in PV module recycling technologies. 2018.

pieces is possible. Low-cost and low energy consumption of this approach has made it the current technique of choice for several players on the market.

**Chemical processes** using selective etching enable the highest value recycling, but come at the expense of considerable chemical use and treatment costs. The most promising recycling approaches use a combination of these different techniques. In an example study the combined mechanical and chemical recycling enabled next wafer recycling the recovery of Cu and Ag (see the table below for the improvement in recycling rate).

Material fraction	Baseline scenario		Thermal and chemical scenario		Delamination scenario	
	kg recov. /Tonne PV waste	% recov. (kg recov./ kg input)	kg recov. /Tonne PV waste	% recov. (kg recov./ kg input)	kg recov. /Tonne PV waste	% recov. (kg recov./ kg input)
Glass	532.94	89.6%	583.23	98%	583.23	98%
Aluminium	130.45	78.1%	144.10	86%	144.10	86%
Steel	80.14	92.7%	84.77	98%	84.77	98%
Copper	13.49	34.7%	33.06	85%	36.95	95%
Silver			0.917	74%	1.18	95%

Figure 65: Comparison of the efficiency of different recycling approaches (Duflluou et al.<sup>22</sup>)

In February 2016, PV CYCLE announced a new record in silicon-based PV module recycling, achieving a 96% recycling rate. Enabling the recycling of silicon flakes – a combination of EVA laminate, silicon-based semiconductors and metals – in a way which is both economical and environmentally sound, the advanced process is currently being applied at one of PV CYCLE’s Europe-based recycling partners for silicon-PV [87].

#### 4.1.2.5 Summary and reference data on the performance and cost of the products and technologies described

PV modules are based on a range of cells technologies which are evolving rapidly in order to improve efficiency and yield as well as with a focus on long term performance and reliability. Following on from the reference year 2016, in which Aluminium back surface field technology can be seen based on its market share to be a suitable base case, it can also be seen that a number of competing cell structures have subsequently been commercialised and could be candidates for BAT. These comprise: PERC family, heterojunction, back contact and bifacial technologies. One alternative that is not yet in the market are epitaxially grown silicon cells that could be considered as a potential candidate for BNAT. Another alternative under R&D is a heterojunction cell based on silicon and perovskite thin film, this is discussed further in the next section.

Beyond the cell technology a number of developments can be identified that relate to the module design and components such as improved and reduced silver/lead content interconnections, the UV protection provided by the backsheet, highly impermeable and UV resistant encapsulants, anti-soiling and self-cleaning front glass, and easily repairable junction boxes and bypass diode.

Current PV modules on the market are not designed for circularity (meaning easy disassembly, repair, refurbishment and recycling). They are not usually designed to be

<sup>22</sup> . R. Duflluou et al, Demanufacturing photovoltaic panels: Comparison of end-of-life treatment strategies for improved resource recovery, CIRP Annals, Volume 67, Issue 1, 2018, Pages 29-32



“re-opened” and the only way for recycling to take place is through destructive processes such as shredding. Such irreversible design severely limits not only the potential for repair/refurbishment, but also the recovery of valuable materials. There are only currently limited examples of module design to support ease of disassembly or dismantling for recycling.

| In summary based on the previous sections, ~~Table 2~~Table 1 displays possible combinations of design improvements at cell level and module level. The cell technology is proposed as starting point for making the combinations because it is fundamental to achieving performance improvements in yield.

Table 2 Base case and Design options for the improvement of crystalline PV modules

	Base case (2016)	cell- PERC PERT, PERL	cell - SHJ	Additional cell- designs cell-Bifacial cell- Back-contact	
				cell- Bifacial	cell- Back- contact
Cell technology	BSF	PERC, <u>PERT, PERL</u>	<u>SHJ</u>	PERC, PERT or IBC (mostly)	IBC, MWT, IBC-HJ
Module efficiency	14.7% (PEF)	18.65% (72 cells) 19.6% (60 cells)	<u>19.7%</u>	+10-20% compared to monofacial modules	<u>25.5%</u>
Cells per module	60	60-72	<u>96</u>	60-72	60
Performance degradation rate (% per year)	0.7%	0.5%	<u>1%<sup>1</sup></u>	0.5%	0.32% <sup>2</sup>
Failure rate modules (%/year)	0.005-0.21% <sup>3</sup>	TBD	<u>TBD</u>	TBD	TBD
Power Temperature Coefficient (%/°C)	- 0.40	-0.37	<u>-0.258</u>	-0.37	-0.29
Module power density (Wp/m <sup>2</sup> )	~ 155-160 (60 cells)	191.5 (72 cells) 195.8 (60 cells)	<u>197.1</u>	210 (72 cells assuming 10% gain) 215,4 (60 cells assuming 10% gain)	211.6
Silicon (g/m <sup>2</sup> Wp)	<u>0.63810</u>	<u>0.5959</u>	<u>0.38315</u>	<u>{0.595}</u>	<u>-15</u>
Compatible with epitaxial wafer	<u>Yes but not yet available.</u>				
Compatible with Pb-free metallisation	Yes. Just being commercialised	<u>Yes and available</u>		<u>Yes. Just being commercialised</u>	
Compatible with reduced Ag metallisation	<u>Yes</u>		=		
Compatible with F-free backsheets	<u>yes</u> Yes	<u>Yes</u>		No yet.	<u>Yes</u>

Formatted Table

Comment [ NIEVESPI 1]: A stakeholder indicates this should be lower, being the efficiency higher: it should be 7.5 g/Wp

Formatted: Superscript

Formatted: Font: Verdana, 9 pt

<b>Cost (EUR/W<sub>p</sub>)</b>	0.48 <sup>3</sup> (see Task 5)	+0.1 <sup>4</sup>	+0.2 <sup>65</sup> ?	+0.14 <sup>5</sup>	+0.02 <sup>57</sup>
<b>Notes</b>					
<p>1. Jordan et al., Progress in Photovoltaics, 2016.</p> <p>2. Mikofski et al., Integrated Model for Predicting PV Performance Degradation over 25+ Years, Sunpower White paper.</p> <p>3. Kurtz S. NREL, reliability and durability of PV modules in Photovoltaic Solar Energy: from fundamentals and applications, John Wiley and Sons, 2017.</p> <p>4. IMEC professionals judgement.</p> <p>5 Judgement of imec PV experts, in view of the PV module price index (<a href="https://www.pv-magazine.com/features/investors/module-price-index/">https://www.pv-magazine.com/features/investors/module-price-index/</a>), based on pvXchange (<a href="https://www.pvxchange.com">https://www.pvxchange.com</a>).</p>					

Formatted Table

Formatted: Superscript

-

Formatted: No bullets or numbering

### 4.1.3 Thin-film module technologies and materials

#### 4.1.3.1 Strict product scope: performance

##### Technology and performance

At present, it is understood that given the market economics it is not possible to make a viable business case for products with module efficiencies below 12%. As a consequence, thin film silicon (either in the form of a-Si, microcrystalline Si, tandem of triple junctions) is rapidly declining in the market, despite the multi-billion investments in upscaled mass production facilities led by Applied Materials and Oerlikon at the turn of the decade. Also dye sensitized solar cells (DSSC) and organic photovoltaics (OPV) so far failed to take this 12% hurdle, and up to this date no substantial scale production was achieved. The two thin film technologies that are able to commercially deliver high performance and yield are CIGS and CdTe.

At this moment, there are only two thin film PV producers on a GW/year scale: First Solar (US) with CdTe on glass (17-18% efficiency), and Calyxo (13% to 15.4). Solar Frontier (J) ~~or MiaSolé (USA)~~ with CIS (ca. 15%-15.4% module) and CIGS on glass (11-17 % efficiency) with CIGS on glass. Both of these products have improved temperature coefficients and spectral response when compared to mainstream crystalline technologies which under certain conditions can improve the yield. Both are in the process of restructuring their production, aimed at short term cost reductions of 20-40%. Of the latter two technologies, First Solar has managed to achieve through successive generations of cell improvements the highest commercialized product efficiencies. The declared module efficiency of the latest series 6 is up to 18%<sup>23</sup>.

At some distance to these market leaders, ~~over a dozen number of~~ producers can be identified with individual manufacturing capacities up to hundreds of MWp/year. However, it should be noted that thin film PV is a declared part of the Chinese PV roadmap, and companies like CNBM, Hanergy and Shanghai Electric are leading a larger group of emerging thin film investors. CNBM alone expressed a 15 GWp ambition based on CIGS and CdTe for the coming years, and started up production on several 100MW scale in the last quarter of 2017. Hanergy has a few companies in their portfolio (MiaSolé, Solibro and Global solar) providing flexible CIGS with high module efficiencies.

<sup>23</sup> First Solar Series 6 Datasheet, available at: <http://www.firstsolar.com/en-EMEA/-/media/First-Solar/Technical-Documents/Series-6-Datasheets/Series-6-Datasheet.ashx>

Formatted: Indent: Left: 0 cm, First line: 0 cm

These products (CIGS on stainless steel foil) are well designed for integration in BIPV products.

GaAs and III-V multijunction devices in general do not yet contribute substantially to earth bound PV electricity production, but have a dominant and proven market position for space applications. Thin film production based on III-V may be brought to larger scale through lift-off techniques enabling re-use of expensive substrates for epitaxial growth. Notable example of such an attempt is the development of a roll to roll lift-off process by Hanergy owned by Alta Devices (US). Another route for more substantial earth-bound application of III-V utilizes their high conversion efficiency under concentrated sunlight conditions, by incorporating them in low cost solar concentrator devices.

Perovskite based thin film PV is not yet in production, but this technology has made remarkable progress in the past few years. Because of its potential of very low cost production, and its suitable bandgap for tandem formation with crystalline silicon, it could be (or pave the way for) a significant and disruptive technology PV energy generation.

For perovskite solar cells, a distinction is to be made for a future with or without lead content. A potential disadvantage of perovskite PV modules is that they currently contain a small amount of lead: approximately 0,5 g/m<sup>2</sup>. This is less than the amount of lead in the junction boxes currently also used for crystalline PV. But because lead could end up in the environment if a solar [panel module](#) were to become damaged and there was water ingress into the module, the extent of the resulting harm and how it could be reduced should be further investigated. Tin, and also the less harmful bismuth are under investigation as a lead replacement. Perovskites could potentially match the functionality of CIGS which currently is virtually unlimited in its applicability to all types of use, on rigid glass as well as on flexible foil.

Regarding the perovskite/Si tandem, recently the start-up Oxford PV has gained a lot of attention by their results showing that the tandem configuration has the potential to outperform single junction Si PV with efficiencies over 22%. They have acquired a production facility in Germany targeting tandem pilot production by 2019-2020.

Thin film technologies are claimed to offer significant improvements in material efficiency when compared to wafer based crystalline technologies. This is because it requires inherently less material and because the production processes are based on vapour deposition on a substrate rather than on the cutting of silicon ingots, which incurs material losses. However, these efficiency gains must be balanced against lower cell efficiencies because of the heterogeneous cell structure. These cell types could have environmental and/or resource efficiency benefits and therefore are an improvement option to explore later in Task 6. The environmental benefits of these cell types can be understood better with reference to the findings of the LCA review in Task 5.

### **Recycling of Thin film PV modules**

Thin-film CIGS and CdTe modules are comprised of 89% and 97% of glass, respectively which enables a higher recycling rate. Their recycling can be conducted through bulk or high-value recycling. For example, the US-based producer of CdTe modules, First solar, provides a circular management of their PV modules. Their recycling process [is operational at industrial scale since 15 years and](#) achieves high recovery rates: it is reported that up to 90% of the semiconductor material can be reused in new modules and 90% of the glass can be reused in new glass products [88].

#### **4.1.3.2 Extended product scope: energy generation potential and reliability under non Standard Test Conditions (STC)**

Some other advantages claimed for thin film PV, sometimes for specific applications are the following:

- Lower temperature coefficient

Every PV module shows a decreasing efficiency with increasing operating temperature, described by the (negative) temperature coefficient. In general, all thin film PV technologies have lower temperature coefficients than crystalline silicon. This gives them an advantage in applications with higher average operating temperatures.

Depending on average operating temperatures over the year, this leads to higher electrical energy output in kWh/Wp when comparing thin film and crystalline PV with the same nameplate efficiencies under standard conditions (25<sup>0</sup> C). First Solar ~~reports claims~~ up to 3% higher output with respect to Si when averaged ~~ed~~ over ~~the lifetime longer~~ periods ~~of time~~.

- Reduced shading loss

A general consequence of monolithic integration of thin film modules, is that they are more tolerant to partial shading than strings of Si cells. Shading of one single cell reduces (stepwise) the total current of an entire string, while monolithically integrated thin film modules only show gradual decrease of total current when increasing parts of the module are shadowed (as long as none of the cell lines is fully covered).

This effect has been shown to lead to notable advantages in PV application on ground and on roofs. For First Solar (focused on utility scale PV on ground) it is an essential element in their strategic choice to reduce BOS costs by going to more densely packed fields of larger size modules.

- Spectral response advantage

~~There is now more substantial evidence form the field of A much debated an~~ advantage of thin film over crystalline silicon ~~concerns in terms of~~ the spectral response under different illumination and weather conditions, averaged over a year of operation. <sup>24,25,26,27</sup> ~~More statistics and modelling are required, but it is to be expected that Under~~ specific climate conditions or module orientations ~~this leads~~ to power outputs which are higher than would be expected under standard certification conditions, as a consequence of response to varying spectral light compositions and angles of incidence (direct/diffuse lighting). ~~Manufacturer First Solar has indicated that based on the use of a commercial software a relative advantage in kWh/Wp energy yield when compared to performance under standard test conditions of 0,5% to 7,5 % for important parts of the world.~~

Formatted: Superscript

- Climate conditions/ relative advantage in kWh/Wp energy yield

To market the thin film CdTe product around the globe, First Solar combined these annual yield advantages as a function of climate conditions in a world map. ~~It indicates a relative advantage in kWh/Wp energy yield when compared to performance under standard test conditions of 0,5% to 7,5 % for important parts of the world.~~

#### 4.1.3.3 Summary and reference data on the performance and cost of the products and technologies described

There are two main technologies that could be considered as BAT because they provide a yield comparable in some cases with silicon based PV technologies. The highest declared yield for a commercially available technology is provided by CdTe cell type. Claims from manufacturers that the material efficiency of the thin film production process outweigh

<sup>24</sup> ~~Dimberger, Daniela, Gina Blackburn, Björn Müller, und Christian Reise. Solar Energy Materials and Solar Cells 132 (Januar 2015): 431–42. <https://doi.org/10.1016/j.solmat.2014.09.034>.~~

Formatted: German(Germany)

<sup>25</sup> ~~Schweiger, Markus, Werner Herrmann, Andreas Gerber, und Uwe Rau. „IET Renewable Power Generation 11, Nr. 5 (12. April 2017): 558–65. <https://doi.org/10.1049/iet-rpg.2016.0682>.~~

Formatted: German(Germany)

<sup>26</sup> ~~Alonso-Abella, M., F. Chenlo, G. Nofuentes, und M. Torres-Ramírez. Energy 67 (April 2014): 435–43.~~

Formatted: German(Germany)

<sup>27</sup> ~~DeLong, Nicholas, und Geoffrey Rich. Conference Paper. 40iest PVSC, 2015.~~

the lower yield compared to the best performer crystalline cell are to be analysed further in Task 5.

On the other hand, perovskite technology either on its own or in tandem with crystalline silicon cells has the potential to provide material efficiency and high yield that could be considered as BNAT since it is not yet being commercialised.

In summary based on the previous section, ~~Table 3~~ ~~Table 2~~ displays possible combinations of design improvements for thin film PV modules.

Table 3. Design options for the improvement of thin film PV modules

	CdTe	CIGS	BNAT	
			Perovskite	Perovskite/Si tandem
<u>Cell technology</u>	CdTe	CIGS	Perovskite	Perovskite/SHJ, PERx
<u>Module efficiency</u>	18.0% (PEF)	15.0%	>22%	>28%
<u>Cells per module</u>	Monolithic	Monolithic	Multijunction	60-72
<u>Performance degradation rate (% per year)</u>	1.0%	1.0%	=	=
<u>Failure rate modules (%/year)</u>	0.2%	0.2%	=	=
<u>Power Temperature Coefficient (%/°C)</u>	- 0.32	-0.36	=	=
<u>Module power density (Wp/m<sup>2</sup>)</u>	146-180	130-170	=	=
<u>Silicon (g/m<sup>2</sup>)</u>	=	=	=	Dependant on tandem
<del>Best commercial performance</del> <del>Not yet available performance</del> <del>Lifetime extension potential</del> <del>Major improvement potential in the bill of materials, process</del>	<del>Cost impact</del> <del>{Scaling of module cost target by 2030}</del> <del>size</del>	<del>Passivation</del> <del>reducing absorber thickness</del>	<del>Overall raising of MRL</del>	<del>Integration of perovskite processing on Si PV cell</del>
<u>Compatible with epitaxial wafer</u> <del>CdTe</del>	±8% Not applicable		±1% Potentially +30y Scaling of module size <0.18 C/Wp	

Formatted Table

Deleted Cells

Formatted: Left

Inserted Cells

Inserted Cells

Inserted Cells

Formatted: Font: Not Bold

Formatted: Font: Not Bold

Formatted: Left

Formatted: Font: Bold

<b>Compatible with Pb-free metallisation</b>	<del>17%</del> Yes. Just being commercialised	<del>20%</del> Lead-free designs are still at R&D stage	<del>+25y</del> Passivation, reducing absorber thickness
<b>Compatible with F-free backsheet</b>	Glass-glass	Glass-glass	-
<b>Cost (EUR/Wp)</b>	<del>1</del> <0.18	<del>23%</del> <0.22	<del>&lt;0.09</del> €/Wp
<b>Perovskite/Si tandem</b>	1	28%	+15y
			Integration of perovskite processing on Si-PV cell
			<0.35 €/Wp

**Deleted Cells**  
Formatted: Left  
Formatted: Left  
Formatted: Font: Bold

**Inserted Cells**  
Formatted: Left  
Formatted: Font: Bold  
Formatted: Superscript

	<b>Best commercial performance</b>	<b>Not yet available performance</b>	<b>Lifetime extension potential</b>	<b>Major improvement potential in the bill of materials, process</b>	<b>Cost impact (module cost target by 2030)</b>
<b>CdTe</b>	18%	21%	+30y	Scaling of module size	<0.18 €/Wp
<b>IGS</b>	17%	20%	+25y	Passivation, reducing absorber thickness	<0.22 €/Wp
<b>Perovskite</b>	1	23%	+15y	Overall raising MRL	<0.09 €/Wp
<b>Perovskite/Si tandem</b>	1	28%	+15y	Integration of perovskite processing on Si-PV cell	<0.35 €/Wp

Formatted  
Formatted: Normal  
Formatted: Font: 9 pt

Formatted: Font: 9 pt

Formatted: Font: 9 pt

Formatted: Font: 9 pt

Formatted: Font: 9 pt

#### 4.1.4 Inverter technologies

##### 4.1.4.1 Introduction to grid coupled photovoltaic inverter technology with standard performance

Photovoltaic inverters are all power conversion equipment (PCE) for use in photovoltaic (PV) to convert electrical power of a PV module to AC. If separated devices are required to do this conversion, the inverter is defined as the sum of the required devices. Examples include PV-string inverters with included MPP-Trackers, the combination of a DC optimizer plus the inverter in systems where both are necessary, micro inverters, etc.

##### Inverter performance and energy efficiency

The basic function of a solar power inverter is to convert the variable direct current (DC) output of a photovoltaic (PV) solar ~~panel~~module into a utility frequency alternating current (AC).

The Euro Efficiency is an averaged operating efficiency over a yearly power distribution corresponding to middle-Europe climate. This was proposed by the Joint Research Center (JRC/Ispra), based on the Ispra climate (Italy), and is now referenced on almost any inverter datasheet. The value of this weighted efficiency is obtained by assigning a percentage of time the inverter resides in a given operating range.

Euro Eff = 0.03 x Eff5% + 0.06 x Eff10% + 0.13 x Eff20% + 0.1 x Eff30% + 0.48 x Eff50% + 0.2 x Eff100%.

~~The inverters~~ It ~~have~~s special functions adapted for use with photovoltaic arrays, for example a maximum power point tracking (MPPT) and an anti-islanding protection function.

The aim of the **maximum power point tracking (MPPT)** function is to obtain the maximum possible power from the PV array. The yield from solar cells has a complex weather dependent relationship between the solar irradiation and temperature. Therefore, the converter needs a real time MPPT control system to obtain the maximum yield out of the cells. Optimisation of MPPT trackers is still an area of research and can make a difference depending on the algorithm such as Perturb & Observe method or incremental resistance method. The **MPPT efficiency** ~~efficiency~~ can be quantified according to a standard (see Task 1).

### Categories of Inverters

Depending on their rating (kVA) and application several **categories of inverters** are on the market as defined in Task 1 and 2, which technologies is discussed hereafter briefly.

One category of inverters that is mainly used in utility-scale power plants are **central inverters** (see Task 1). They have a rated capacity up to 4 MW and a euro efficiency that varies between 97.5% and 98.6% [1]. In architectures using central inverters, strings are parallel-connected in DC combined boxes; then the output of such combiner boxes are connected to the central inverter. Central inverters typically have one MPPT. The main disadvantage is that mismatch losses increase whenever the system is working under non-uniform conditions, such as partial shading along with higher installation cost and larger inverter footprint. Main advantages are simplicity in design and connection, and low O&M overhead [93].

Another category of inverters are **string inverters (see Task 1)**. String inverters have a wide range of capacities, from few kW up to 166 kW-AC, ~~That-that~~ makes them suitable for all kind of applications: from residential to utility-scale. Single-phase string inverters have a capacity of up to 6 kW, thus they are mainly used in residential applications. Commercial and utility-scale PV systems use instead three-phase string inverters. String inverters deployment in utility-scale PV systems is becoming the new trend for certain applications. The continuous decrease of cost, together with the increase of voltage (up to 1500 V) during the last years drove such a change. The euro efficiency of string inverters typically varies between 95% and 98.2% [94]. String inverters usually have multiple input channels, each channel implementing an independent MPPT. This reduces mismatch losses in comparison to central inverters. However, architectures based on the use of multiple string inverters are still more expensive. High-power string inverters (125 to 166 kW-AC) usually have a single MPPT tracker.

DC power optimizers and microinverters together known as **Module-level power electronic (MLPE) converters**, are mostly used in residential and commercial application. Whereas it is not deployed in utility-scale PV systems, they are a fast growing market segment in solar industry (see Task 2). **Performance improvement with MLPE is expected when one or more modules may be shaded or modules are subjected to different irradiation levels**, e.g. when modules are installed in different orientations, or there is shading from the environment (e.g. from a chimney, or



a tree) or a module mismatch on PV system performance. The two main classes of MLPE are [95]:

1. **String/central inverters with module-level DC power optimizers:** small DC/DC converters are installed on every module to perform module-level MPPT. Then, outputs of power optimizers are connected, usually in series, to the string inverter. The largest manufacturer of such devices is SolarEdge that recently presented a new single-phase string inverter designed ad-hoc for such application. ~~Since the MPPT is done per module by the power optimizers, the inverter(s) would have a fixed string voltage that allows for continuous operation at the highest efficiency, leading to an euro efficiency of 99% [96].~~ The main advantage of such solutions are:
  - Module-level MPPT.
  - Safety requirements as rapid shutdown implemented per module.
  - Monitoring per module.
2. **Microinverters** represent an alternative to the use of power optimizers and string/central inverters. They perform both MPPT and DC-to-AC conversion per module therefore providing the same advantages in euro efficiency terms as an optimiser at module-level. The main advantages of microinverters are:
  - Independent functioning: if there are problems with one of the modules or one of the microinverters into the system, the other modules keep on working normally.
  - The use of microinverters implies that there are no points with high DC voltage in the system, thus enhancing safety.
  - Monitoring per module.

The main disadvantage nowadays is represented by their high cost. The largest microinverter manufacturer nowadays is Enphase Energy. Enphase microinverters euro efficiency is declared at 97.5% [97]. They are designed for connection to a single module, thus they have a single input channel. A different approach has been followed by manufacturer AP systems, that produces microinverters that have multiple MPPT channels (2 or 4) [98], so that multiple modules can be connected independently at the various channels. The euro efficiency of AP systems microinverters ranges between 94% and 96%. ~~The temperature resistance of MLPE is also a critical parameter to consider. As the modules are installed on roofs, considering the temperature resistance helps preventing degradation, reduced lifetime or adjusting the conditions of the guarantee. The operating temperature range of MLPE should be aligned with temperature observed on roofs (65°C-85°C).~~

3. ~~DC/DC Optimisers are a slightly different concept than SolarEdge DC-DC MPPT optimizers plus fixed-voltage inverters. The MPPT is still done by the string inverter for the full string, and the optimizer adjusts the current of modules deviating from the main direction of the PV plant. These MLPE can be used with various inverters and need not be installed on every module of a PV installation - in contrast with installations based on microinverters.~~

As mentioned before the euro efficiency in standard conditions of these photovoltaic converters is high (>95 % peak). The achievement of a **higher inverter efficiency** today and the differentiation on the market is due to the availability of new power components in the field of semi-conductors and magnetics, as well as to different power topology designs depend on the following:

- 80% of losses takes place in switching of power semiconductor like IGBT and AC inductors [99].
- The number of levels in the converter topology causes a difference in efficiency

**Formatted:** Font: Bold

**Formatted:** Indent: Left: 0.63 cm,  
Numbered+ Level: 1 + Numbering  
Style: 1, 2, 3, ... + Startat: 1 +  
Alignment: Left + Alignedat: 1.9 cm  
+ Indentat: 2.54 cm

- Cooling methodology of these power semiconductor devices like air-flow

For designing PV inverters more than 50 topologies are known and/or on the market today [100]. Improving the efficiency at high load results in an oversizing of parts: more copper, semiconductors with more silicon and an increased cost. The efficiency improvement at no load levels is achievable with: a better design with smarter digital control, reduction of energy losses and reduction in auxiliary circuits" (internal power supply, fans, coils, etc.), improved bleeder resistor circuits, diode and transistor leakage currents and lower magnetic losses with improved magnetic materials for inductors and transformers. The purpose of a bleeder resistor is to discharge filter capacitors when the equipment is turned off for safety reasons. For energy savings the bleeder resistor should be disconnected under normal operation, but this comes at the extra cost of a more complex circuit. The same might apply to inrush current protection circuits to protect the DC bus capacitors.

In general, PV inverters found today on the market are at the state of the art in energy efficiency and have most of these improvement options already to a high extent. This is probably due to the high value of PV generated electricity and the market awareness already for inverter efficiency. Despite this, there is still some differentiation in inverter efficiencies that can be found in the market. The most known and complete database of PV inverter efficiency is the **PHOTON** database<sup>28</sup>. Future inverters can still be expected to become more efficient due to new **wide bandgap semiconductors** (WBG), such as silicon carbide (SiC) and gallium nitride (GaN) used in MOSFETs<sup>29</sup> [101], [102]. Apart from being more efficient they will have a positive impact on the volume and weight of the cooling and housing.

In terms of power electronic converter technology, and bill of materials photovoltaic inverters, sources of failures and life time issues are considered to be similar to Uninterruptable Power Supplies (ENER Lot 27), LED or fluorescent lamp drivers (ENER Lot 19) and motor drives (ENER Lot 30).

### Protection methods implemented in Inverters

The role of the **anti-islanding** protection function is to protect power system equipment, utility workers and allow to disable the PV inverter, in case, grid enters into island condition. In its absence and during a grid fault, the feeder continues to be energized if the load matches the PV generation making safety and reliability concerns [89]. Therefore, the anti-islanding protection will shut down the PV inverter within 2 seconds when a grid anomaly is detected such as a fault. It is an important function in grids with distributed generation, for photovoltaics mainly systems installed in the low voltage distribution system (230 VAC).

Another function sometimes added to inverters is a **frequency control** function. This function will limit the injected power in case of oversupply and grid unbalance. It depends on the local grid code and the size of installation to determine the requirement of this function. The response to frequency deviations of devices connected to the network can potentially have an adverse impact on the operation of the power system. In 2005-06, Germany introduced a requirement that all generating plants connected to the low voltage network, including PV, must switch off immediately if power system frequency increased to 50.2 Hz [90].

Similarly most inverters have a **grid overvoltage** control function, which limits the power injection at high grid voltages. The overvoltage control function is important in congested low voltage distribution grids. Therefore, if the voltage reaches to 1.10 per unit because of PV injection then the inverter will be disabled automatically. It has an impact on the performance ratio, see Task 3. This function is sometimes combined with a **reactive power injection** function. The reactive power injection function or Q on-

<sup>28</sup> <https://www.photon.info/en/photon-databases>

<sup>29</sup> Metal oxide semiconductor field effect transistor (MOSFET)

demand can remediate grid over-voltages and help in reducing the burden on utility grids. However, it will decrease the operating efficiency of the inverter and therefore affect the performance ratio, see Task3.

Under standard conditions, inverter efficiency is defined at unity power factor or in other words without reactive power injection. If there is a requirement from the grid operator to foresee reactive power compensation, this can result in an inevitable need to either oversize the inverter in order to supply both peak active and reactive power or to decrease the efficiency.

Moreover, the input voltage and current range of the inverter should match with the expected output of the modules, which will impact the Performance Ratio (see Task 3). It is the role of the PV system designer to select the correct inverter and to avoid this loss of performance (see Task 3). A monitoring function can reveal such a mismatch between the input current and voltages and expected output.

The **earthing and the galvanic isolation** of PV system are other important aspects which relate to safety of a device and personnel, insulation safety requirements as well as protection against failures due to overvoltage induced by lightning [91]. There are mainly two different inverter connection technologies and therefore, protection (isolation) schemes. Therefore, according to the isolation there are two types of photovoltaic inverters that can be found in the market:

- **Inverters with transformers** provide galvanic isolation from the grid and operate at either low frequency (50 Hz) or high frequency. These are utilised with the grounded PV modules. Nonetheless, the transformers cause additional losses and especially decrease efficiency at low yield due to the no load losses of these transformers. These inverters with transformers have usually an Insulation Monitoring Device (IMD) incorporated that will shut down the inverter only in case of an insulation failure (e.g. water infiltration).
- **Transformer-less inverters** provide no galvanic isolation to the PV modules to the grid that means a failure in the dc side of modules will propagate to the ac side and therefore, trip its residual current detector (RCD). An important benefit of these inverters is their higher efficiency. A design challenge for the transformer-less inverters is to prevent the DC fault current from being supplied to the AC grid since they do not have electrical isolation between DC and AC circuits. This may raise some grounding and/or lightning protection concerns [92].

Apart from heat and humidity, the earthing concept and the voltage of the PV cells relative to earth potential can have an impact on Potential-induced degradation (PID).

There is a trade-off between efficiency and system reliability when choosing between an inverter with or without transformer. Therefore **when considering inverter efficiency**, later on, **one has to compare both types of inverters**.

### **Life time and inverter failures**

For inverters the **life time** is defined as the time span for which an inverter is considered to function as required, under defined conditions of use, until for the specific type of inverter an unacceptable level of failure is reached, the level of which is to be defined.

It is important to note that the system level lifetime prediction should be calculated accurately using both quantitative and qualitative lifetime modelling in order to give preciseness to the prediction. These three factors play an important role in predicting system lifetime:

- Junction temperature (solder fatigue due to uneven current distribution at solder joint)
- Gate oxide breakdown (Gate failure due to higher electric field across oxide)
- Body diode degradation (Diode failure due to high variation of voltage in time)

Field failure studies performed on different PV systems (residential, commercial and utility-scale ones) have shown that PV inverter failures represent the main reason for a PV system failure. The inverter is cited as being responsible by far for the largest percentage of service calls between 43% and 70%, which leads to higher maintenance costs and lost power production [103]. The inverter has also been reported to be the greatest factor leading to energy outages, responsible for up to 36% of the energy loss.

Inverters are composed of different components the failure of each can result in downtime and power loss of the inverter. [Table 4Table 3](#) presents an overview of rates of failure of inverter components. According to field studies, the key components that have the higher rate of failure and likely lead to inverter replacement are PCBs, solid-state switching devices and capacitors [73][103]. Other components as AC contactors, fuses, fans also have high rate of failure. However, they mainly imply repair of the inverter rather than replacement.

Among all sources of failures, 55% of failures in PV inverters are reported to be thermally induced. This is because of the irregular thermal profiles and the mismatch of the thermal expansion coefficient leading to mechanical stress to bond wires and solder joints [108]. To overcome this, SiC MOSFET based power modules have been given attention in comparison to Si based inverter because of their better performance in high power applications, high temperature tolerance, lesser volume and high efficiency.

Another frequently occurring failure mode identified is related to control software or firmware. It is significant enough to be the first or second greatest cause of power loss events for inverters, and could be linked to some of the components failures identified in [Figure 7 and Table 4Table 3](#).

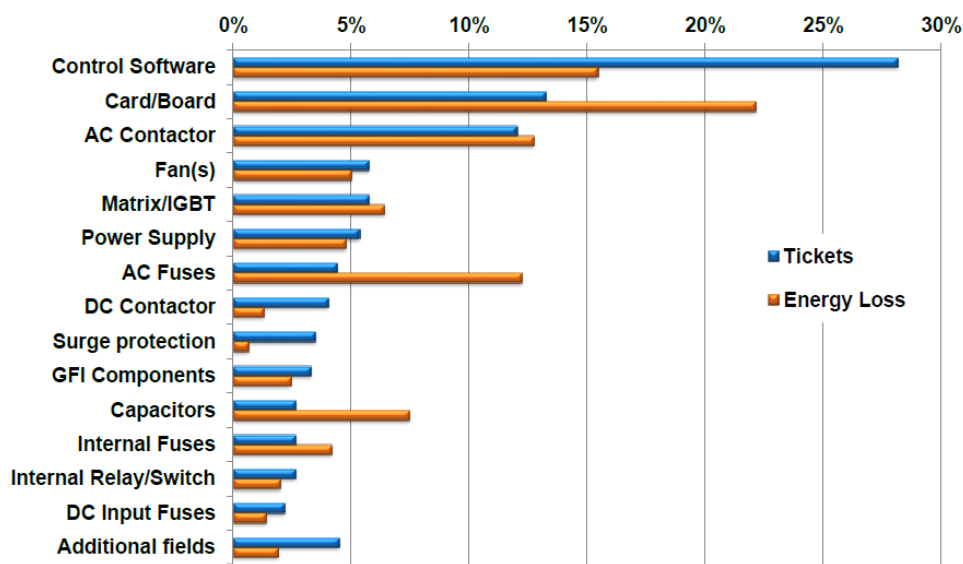

Figure 7. Inverters components that fail, from PV System Reliability: An Operator's Perspective, Golnas and Voss, SunEdison

Formatted:  
Caption; Eco\_Caption; Legend; Figure reference; Tab\_Überschrift; Caption Char1; Caption Char2; Caption Char3; Caption Char4; Caption Char5; Caption Char6; Caption Char7; Caption Char8; Caption Char9; Caption Char10

Table 4 Frequency of failure tickets and associated energy loss for each general failure area [105]

Inverter Failure Area	% of Tickets	% of kWh lost
No-Fault-Found Failures	28%	15%
Card/Board	13%	22%
AC Contactor	12%	13%
Fan(s)	6%	5%
Matrix/IGBT	6%	6%
Power Supply	5%	5%
AC Fuses	4%	12%
DC Contactor	4%	1%
Surge Protection	3%	1%
GFI Components	3%	2%
Capacitors	3%	7%
Internal Fuses	3%	4%
Internal Relay/Switch	3%	2%
DC Input Fuses	2%	1%
Other	5%	2%

One should be aware that during the last decade power electronics have progressed significantly and inverter designs have been upgraded. Therefore failure statistics found today for installed products are not necessarily representative for new products. Inverter failures do not necessarily imply inverter replacement. According to an IEA Task 13 report on financing[104] (p. 52), the life of an inverter is considered to be between 10-15 years. According to that report the technical lifetime of the PV system in general and the inverter follows a so-called bathtub failure profile with more 'early life' and 'wear out' failures in the beginning and the end.

PV inverter warranties depend on the technology and the rated power, as well as on the manufacturer. Standard warranty of string inverters is 10 years [106]. However, some manufacturers offer an extended warranty up to 15 or 20 years. Also, there are still some manufacturers giving only a 5 year warranty, mainly on high-power inverters. The warranty of microinverters from APsystems is similar to the one of string inverters (10 years standard with optional 15-years extension). However, microinverters from Enphase have a 25 years warranty. This warranty for the hardware costs only may have a limited value, as the labour costs for the exchange on the roof may be largest costs. It has also to be noted that such micro-inverters have only been deployed in the field for a few years, thus there is no proof of such a long lifetime. Larger central inverters are modular and on site repair is a common practice, often forming part of a service contract (see Task 3).

Ensuring longer lifetime is also important because after 10-15 years from the date of installation it may be not possible to find an equivalent replacement having the same form, or fit, or functionality. As an example from the past, the typical rated voltage of utility-scale central inverters has changed from 600 V to 1500 V in ten years [107]

A longer lifetime can be achieved in different ways. Reducing the total number of components usually leads to increased reliability, given the less possible points of failure. Wide-bandgap technologies as Silicon Carbide (SiC), that can handle higher voltages compared to current semiconductor devices, might enable simpler inverter topologies [PVTP13]. However, as already stated before, the lifetime of SiC transistors still needs to be proven, although some literature studying lifetime prediction for SiC-based inverters is becoming available recently [YY].

Proper selection of electrical components, both active and passive, is core to ensure longer lifetime. The rated current and voltage of each component must be selected according to worst-case analysis and taking into account both normal and abnormal operating conditions, e.g. higher operating temperature due to issues with the fans or dust entrance, as well as the interaction between the components within the inverter during operation. Ratings must be good enough to ensure the longest lifetime of each component.

### PV inverter repairability

The availability of an inverter is a number based on the reliability and repairs, and there is an operating cost to secure a given availability of inverters. A higher repairability is desired to minimize unplanned or unexpected outages, and minimize repair and power restoration times. While it is economically impractical to attain inverters that never fail or need maintenance, or achieve 100% availability, the impact of inverter outages on the revenue streams of PV projects must be recognized in any case. These aspects motivate the use of reliability testing and quality standards utilizing quality management principle to reduce the unpredictability of operating costs for owners and operators. As it was identified in the previous section there are certain components of the inverter that favour repair rather than replacement. These are understood to include AC contactors, fuses, fans which can have a relatively high rate of failure.

For some of these components the possibility of repair/replacement may depend on their significance according to potential performance losses. As can be seen in [Figure 8](#)[Figure 6](#), the cost of inverter repair is in general relatively low when compared with the output losses (see also [Figure 4](#)[Figure 3](#) in which the situation is the reversed).

~~Besides internal damage, which can often be lead back to component fatigue, lightning and overvoltage can be the cause of damage. If your inverter breaks down because of lightning or overvoltage, the insurance company usually answers for the damages. Within the warranty period, internal damage is born by the manufacturer. An inverter damage report will provide a clear indication on the cause of damage and damaged components. Besides internal damage, component fatigue, lightning and overvoltage can be other causes of damage. If the inverter breaks down because of lightning or overvoltage, the damage would usually be covered by an insurance company. Within the warranty period, claims relating to internal damage are born by the manufacturer.<sup>29</sup> Besides internal damage, which can often be lead back to component fatigue, lightning and overvoltage can be the cause of damage. If your inverter breaks down because of lightning or overvoltage, the insurance company usually answers for the damages. Within the warranty period, internal damage is born by the manufacturer.~~

Formatted: Font: (Default)Verdana  
10 pt, Fontcolor: A uto,NotHidden

Formatted: DefaultParagraphFont,  
Superscript

Formatted: Font: (Default)Verdana  
10 pt, Fontcolor: A uto,NotHidden

<sup>29</sup> <https://www.secondsol.com/en/services/pv-wechselrichter-reparatur.htm>

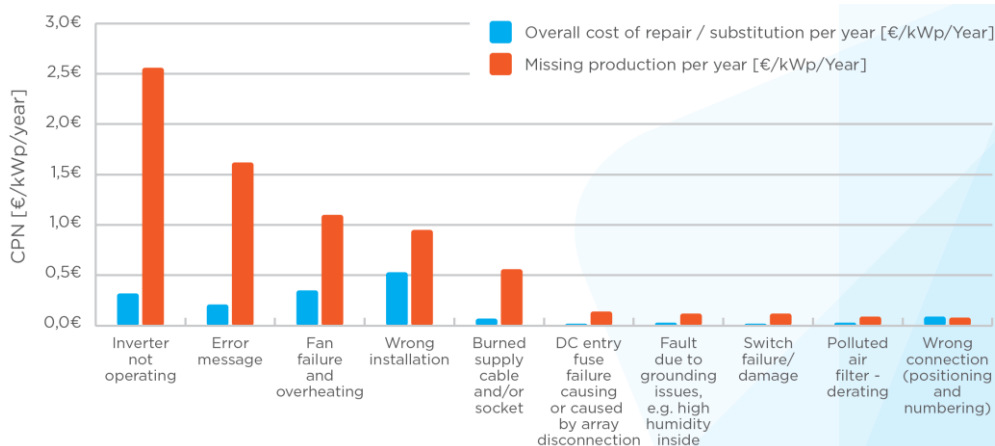

Figure 86. Costs during operation and maintenance (CPN), repair costs ( $CPN_{\text{failure}_{\text{to}}}$ ) and performance losses ( $CPN_{\text{never}_{\text{detected}}}$ ) for top 10 risks for PV inverters of all system sizes. Source: Solar bankability, 2017.

Besides internal damage, which can often be lead back to component fatigue, lightning and overvoltage can be the cause of damage. If your inverter breaks down because of lightning or overvoltage, the insurance company usually answers for the damages. Within the warranty period, internal damage is born by the manufacturer. An inverter damage report will provide a clear indication on the cause of damage and damaged components. Besides internal damage, component fatigue, lightning and overvoltage can be other causes of damage. If the inverter breaks down because of lightning or overvoltage, the damage would usually be covered by an insurance company. Within the warranty period, claims relating to internal damage are born by the manufacturer<sup>31</sup>. Besides internal damage, which can often be lead back to component fatigue, lightning and overvoltage can be the cause of damage. If your inverter breaks down because of lightning or overvoltage, the insurance company usually answers for the damages. Within the warranty period, internal damage is born by the manufacturer.

### Recycling of inverters

This follows the same route and procedures as other power electronics that are in the scope of the WEEE Directive [111] and to our knowledge there are not currently any relevant exemptions for hazardous substances (ROHS Directive) to be mentioned here. The majority of the bill of materials of an inverter consists of the external housing made of sheet metal which could be steel or aluminium, aluminium heat sinks, and the internal structure. Commentators suggest that plastic housing may be used in the used in the future with polycarbonate cited, which may create challenges for recycling. Then, in terms of the electrical components, the inductors, circuit board and connectors contain metals of higher value. And it is these components could be the target for ease of dismantling for the purpose of recycling.

### Monitoring function added in the inverter

**Adding performance monitoring** to the inverter is also an improvement option. Ideally, proper monitoring and diagnostics would support a decision for repair vs. replacement. The benefits were already discussed in Task 3 and will also be discussed in a later section on system performance.

<sup>31</sup> [https://www.secondsol.com/en/services/pv\\_wechselrichter\\_reparatur.htm](https://www.secondsol.com/en/services/pv_wechselrichter_reparatur.htm)

#### 4.1.4.2 Introduction to grid coupled inverters with combined battery storage function and prospect for future DCgrid applications

Battery energy storage is a collection of methods used to store electrical energy on a large scale within an electrical power grid<sup>32</sup>. Battery systems connected to large solid-state converters have been used to stabilize power distribution networks. Some grid batteries are co-located with renewable energy plants, either to smooth the power supplied by the intermittent wind or solar output, or to shift the power output into other hours of the day when the renewable plant cannot produce power directly. These hybrid systems (generation + storage) can either alleviate the pressure on the grid when connecting renewable sources or be used to contribute to greater self-consumption.

There are three principle configurations that can be used for connecting PV and battery systems – AC coupled, DC coupled and generator coupled (see Figure 9Figure-5). In the below section AC coupled system is briefly analysed. The majority of residential PV systems installed in the EU are understood to have AC coupled configurations.

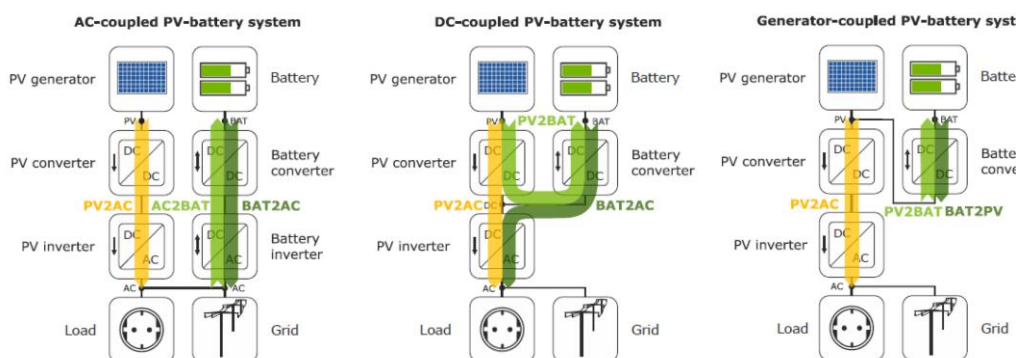

Figure 97. System topologies for connecting PV modules and batteries.

The Effibat project is working towards developing a standard for the comparison of the efficiency of battery systems. This standard will be based on a metric which will aggregate five types of losses that have been identified in what they call system performance index (see Figure 10Figure-6). This index does not address the intrinsic performance and lifespan of the battery itself.

<sup>32</sup> I. Gyuk, P. Kulkarni, J. H. Sayer, J. D. Boyes, G. P. Corey, and G. H. Peek, "The United States of storage," IEEE Power Energy Mag., vol. 3, no. 2, pp. 31–39, 2005.



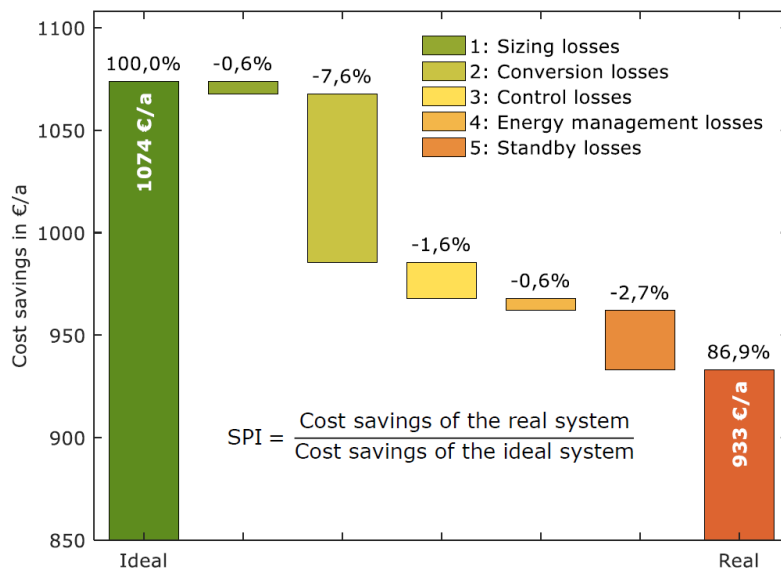

Figure 108. PV output 5 kWp, battery capacity 3,7 kWh, load demand 5 MWh/a, feed-in tariff 12 ct/kWh, retail price 28 ct/kWh

### Batteries connected on the AC side of the inverter

It is possible to have battery storage connected with a charger/inverter or bidirectional converter to the AC grid. Those are referred as AC coupled battery systems, see Figure 9Figure-5, i.e. an AC integrated battery/PV system. Those systems can be installed anywhere irrespective of a PV system or any other system being connected behind the meter in the AC grid. It is in principle not related to PV system but is an indirect consequence of its variable production and the potential mismatch with the local loads, see Task 3 for more details.

### Batteries connected on the DC bus of the PV inverter

The efficiency of systems where PV is combined with storage is strongly dependent on how many AC/DC and DC/AC conversions are performed: the number of conversion stages should be minimized to increase efficiency. Thus, **the battery storage should be preferably implemented on the DC side**, namely the inverter input, where PV strings are connected. The other option, meaning a connection on the AC side, would reduce the overall efficiency. However, it would represent the easiest solution for connection of batteries to already existing systems, since it allows for a direct connection of the battery controller/charger to the system output, namely the inverter output.

Few ~~Several~~ examples of inverters with combined battery storage can be already found on the market, like the [Fronius Symo Hybrid 5.0-3-S30 kW Stabiliti Multiport Power Conversion System](#) [112]. In principle there is no negative impact from incorporating battery storage on the DC side of an inverter, however in some protection topologies a grid coupled inverter with transformer might be required, see previous section 4.1.4.1, and as mentioned there they have lower efficiency compared to transformer-less designs.

Note that batteries are part of another Ecodesign study: <https://ecodesignbatteries.eu/>

Field CodeChanged

### The option of a DC distribution grid

A relative new development but not available in the market yet is to connect the PV modules and the battery to a **DC distribution grid** incorporating also DC loads instead of AC. The concept of DC grid with its many advantages over AC like improvement in efficiency is capturing the industries and markets. It is able to garner relatively good

support and momentum on this technology. Many loads or applications today are essentially DC-based, e.g. an inverter driven heat pumps, ICT, LED lighting, fire alarm etc. Thus, by deploying a DC distribution rather than conventional AC, a number of conversion steps can be eliminated and therefore, losses as well. This is a new development that requires new standardisations and at member state level early initiative are ongoing [113] TBC [114]. For example, this might require a standardized DC voltage that is accessible to other applications.

**4.1.4.3 Summary of the technical improvement options and impact on Performance, Bill of Material and product price for inverters**

In summary based on the previous section the following base cases (BC), and possible combinations of design improvements have been identified for inverters (see ~~Table 4 Table 5, Table 6 Table 5 and Table 7 Table 6~~). -These comprise:

- The 'Base Case'(BC) as an average performing inverter wherein:
  - BC 1: is a 2.5 kW<sub>p</sub> transformer-less single phase string inverter
  - BC 2: is a 20 kW<sub>p</sub> transformer-less three phase string inverter
  - BC 3: is a large central inverter 1500 kW
- The following improvement options have been identified as potential candidates for BAT:
  - To change from average inverter efficiency to the best commercially available, referred as BC-EE options in ~~Table 5 Table 4, Table 6 Table 5 and Table 7 Table 6~~.
  - To extend the life time and to ensure ease of repair referred as BC - repair in
  - Table 5 Table 4, Table 6 Table 5 (note: large central inverters are assumed to be repaired by default)
  - To add the monitoring function in BC 1 and 2, referred as BC - monitor in ~~Table 5 Table 4 and Table 6 Table 5~~ (note: in large systems BC 3 this feature can be added at system level and not at the level of the inverter, a certain degree of remote monitoring of the inverter malfunctioning is assumed as a default feature).
  - To shift to module level converters in BC 1 which is referred as BC1- MLI
- The following improvement options not yet commercially available have been identified as potential BNAT:
  - To use Wide Band Gap materials to improve the inverter efficiency, which is BC - WBG in
  - Table 5 Table 4, Table 6 Table 5 and Table 7 Table 6.

Extending the life time of an inverter and ensuring it can be repaired are potentially important topics to reduce its environmental impact to be assessed in Tasks 5 and 6. This should be done with the following definitions:

- Technical life time of an inverter [years]: is the average time between the putting into service and the failure of an inverter in real conditions, which can also be modelled by the Mean Time Between Failure (MTBF).
- Failure rate inverter[%/y]: This is the linear average failure rate per year of an inverter relative to its technical life time (= 1/MTBF<sub>inv</sub>). The average data for Annual failure rate is based on Table 15 from Task 3.

•

Formatted: JRC\_TextLeft, Bulleted + Level:2 + A lignedat: 1.9 cm + Indentat: 2.54 cm

Formatted: JRC\_TextLeft, Bulleted + Level:2 + A lignedat: 1.9 cm + Indentat: 2.54 cm

Formatted: JRC\_TextLeft, Bulleted + Level:2 + A lignedat: 1.9 cm + Indentat: 2.54 cm

Formatted: JRC\_TextLeft, Bulleted + Level:2 + A lignedat: 1.9 cm + Indentat: 2.54 cm

Formatted: JRC\_TextLeft, Bulleted + Level:1 + A lignedat: 0.63 cm + Indentat: 1.27 cm

Table 5 Base Case 1 single phase string inverters and improvement options

	BC1- phase 1 (BC1)	BC1-EE (More efficient)	BC1- repair (repaired)	BC1- monitor	BC1- MLI (module level converter)	BC1- WBG EE- (wide band gap converter)
<b>Rating [kVA]</b>	2.5	2.5	2.5	2.5	10x250	2.5
<b>Topology</b>	Transformer-less String 1phase	See BC1	See BC1	BC1 + monitoring	Transformer-less module level inverter	BC1 with WBG
<b>Euro Efficiency <math>\eta_{conv}</math> [%]</b>	96	98	96	-	97	99
<b>DR<sub>shading</sub></b>	0.96	0.96	0.96	0.96	0.99	0.96
<b>Repaired components assumption</b>	none	TBD	Components as identified	TBD	Components as identified	Components as identified
<b>Impact on cooling BOM &amp; housing</b>	100 %	+5%	BC1	+5%	TBD	-30 %
<b>Cost impact</b>	100 %	+10-20%	100-200 euro/repair incident	100-200 euro/repair incident	+100 -200 %	TBD
<b>Failure rate inverters (%/year)</b>	10 %	10 %	10 % anticipated lower replacement rate	TBD	10 %	TBD
<u>(1) Based on the assumption of the assumption that the life time is extended by replacing.</u>						

Formatted: Font: 8 pt

Formatted: JRC\_Text, No bullets or numbering

Formatted: Font: 9 pt

Formatted: Normal

(1) Based on the assumption of the assumption that the life time is extended by replacing.

Table 6 Base Case 2 three phase string inverters and improvement options

	BC2 phase -3 (BC1)	BC2- EE (More efficient)	BC2- repair (repaired)	BC2- monitor	BC2- WBG EE- (wide band gap converter)
<b>Rating [kW]</b>	20	20	20	20	20

<b>Topology</b>	Transformerless String 3-phase	See BC2	See BC2	BC2 + monitoring	BC2 with WBG
<b>Euro Efficiency</b> $\eta_{conv}[\%]$	97%	98%	97%	97%	99%
<b>Repaired components assumption</b>	none	TBD	Components as identified	TBD	Components as identified
<b>Impact on cooling BOM &amp; housing</b>	100%	+0%	TBD	+5%	-30%
<b>Failure rate inverters</b> (%/year)	Below 10%	Below 10%	Below 10%	Below 10%	Below 10%
<b>Cost impact</b>	100 %	<del>+10-1</del> -20 %	400-800 euro/repair incident	200-400 euro/repair incident	TBD

**Comment [ NIEVESPI2]:** Check this cost

**Formatted:** Normal

Table 7 Base Case 3 large central inverters and improvement options

	<b>BC 3 (BC3)</b>	<b>BC3- EE (More efficient)</b>	<b>BC3- EE-WBG (wide band gap converter)</b>
<b>Typ. Rating[kW]</b>	Central inverter TBD	See BC3	BC3 with WBG
<b>Topology</b>	Connected to LV transformer	See BC3	New
<b>Euro Efficiency <math>\eta_{conv}[\%]</math></b>	97%	98%	99%
<b>Impact on volume</b>	100%	105%	70%
<b>Impact on cooling BOM &amp; housing</b>	100%	105%	70%
<b>Cost impact</b>	100 %	+10 -20 %	TBD

**Formatted Table**

Failure rate of active components <b>in inverters</b> (%/year)	Below 10 %	Below 10 %	Below 10 %
--	------------	------------	------------

#### 4.1.5 PV system level technologies and practices

The role of a good design, maintenance and monitoring is important in any PV system has already been discussed in detail in Task 3. Some specific aspects of these three points will be further analysed here.

Formatted: JRC\_Text

The balance of system (BOS) encompasses all components of a photovoltaic system and this represents more than the previously discussed PV modules and inverters. The parts that can also have an impact on the performance and yield are the wiring and the monitoring system. They will be discussed hereafter in more detail.

Note that Building Integrated Photovoltaic (BIPV) systems will be discussed in a separate section 4.1.6.

##### 4.1.5.1 Introduction to PV system level technology and improvement

###### options Technology selection as a response to real climatic conditions

Different PV modules technologies show different effects of deviations from STC observed for irradiance, module temperature, spectral composition of irradiance and angle of incidence<sup>33</sup>. The role of a good design, maintenance and monitoring is important in any PV system has already been discussed in detail in Task 3. Some specific aspects of these three points will be further analysed here.

The balance of system (BOS) encompasses all components of a photovoltaic system and this represents more than the previously discussed PV modules and inverters. The parts that can also have an impact on the performance and yield are the wiring and the monitoring system. They will be discussed hereafter in more detail.

4.1.5 Note that Building Integrated Photovoltaic (BIPV) systems will be discussed in a separate section 4.1.6.

Formatted: JRC\_Text

##### 4.1.5.1.1.1 Introduction to PV system level technology and improvement options

The role of a good design, maintenance and monitoring is important in any PV system has already been discussed in detail in Task 3. Some specific aspects of these three points will be further analysed here.

The balance of system (BOS) encompasses all components of a photovoltaic system and this represents more than the previously discussed PV modules and inverters. The parts that can also have an impact on the performance and yield are the wiring and the monitoring system. They will be discussed hereafter in more detail.

Note that Building Integrated Photovoltaic (BIPV) systems will be discussed in a separate section 4.1.6. These factors have been described in Task 3 and will be analysed further in the system design options (tasks 6 and 7).

Field CodeChanged

<sup>33</sup> Prog. Photovolt: Res. Appl. 2017; 25:218-232  
Prog Photovolt: Res Appl. 2018; 26:74-85.

#### 4.1.5.2 PV system design software

Current commercial PV plants and ever increasing utility scales PV plants require adapted software solution to design the physical layout, installation conditions and electrical architecture of the system. For larger systems, maximizing land usage i.e. installation of highest number of PV modules, has been the driving principle of the design. However, the clear paradigm shift towards optimization of PV plants to achieve the highest energy yield instead of the highest capacity installation requires the use of more advanced PV system design solutions.

From an investors perspective reference is also made to a probabilistic assessment of yield uncertainty. For example, software package PVSyst can identify the uncertainty at different percentiles (see [Figure 11](#)). Different components of the yield assessment have their own uncertainty range and mitigation measures can be used to reduce the uncertainty, e.g. the temperature model, the climatic variability, etc.

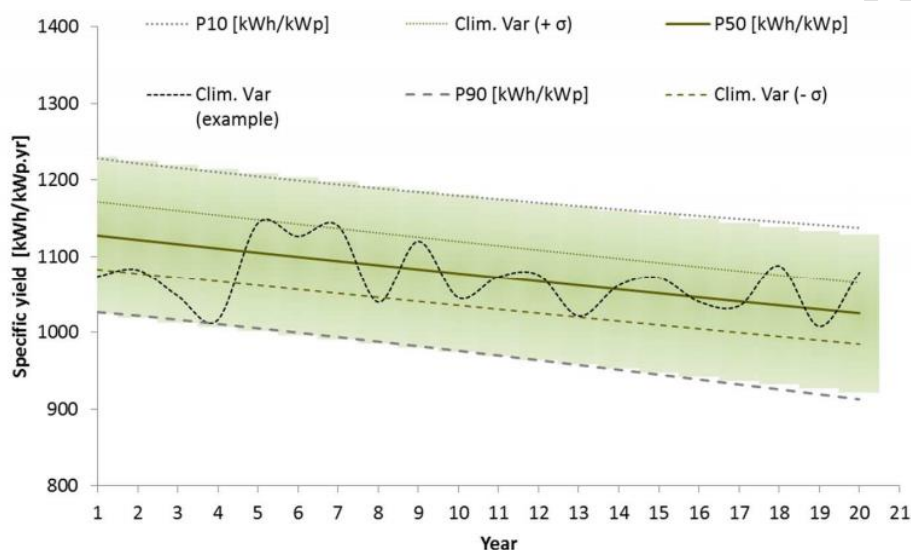

Figure 119. Yearly expected mean specific yield (P50) and its exceedance probabilities (P10 and P90) for each year of the economic life of the project. Source: Solar bankability <sup>34</sup>

The deployment of new technologies to optimise performance such as bifacial PV modules and/or trackers, requires additional consideration of shading patterns/reflectivity. With the increasing share of renewables in the electrical grid, solutions proposing peak shaving or other specific requirements for the local grid are favoured in some cases.

The energy yield of a bifacial system is more dependent on the mounting and conditions of the ground than for monofacial systems as they harvest light also on their rear side. Four different installation conditions can be distinguished: fixed tilt, vertical and one or double axis tracking. To define optimal installation conditions of bifacial systems the interlinked impact of system height, module orientation, row spacing and ground reflectivity (albedo) need to be considered. To minimize mismatch losses, optimal electrical layout of the bifacial PV system resolving the impact of varying rear-side shading conditions within one string and in between strings as well as the use additional module level power optimization must be also considered.

The types and form of the supporting structure of the modules for bifacial systems should be equally adapted to minimize back-side shading by using cable guides and enable safe

<sup>34</sup> D3.1. Review and gap analysis of technical assumptions in PV electricity cost. Solar bankability, 2016

clamping of frameless modules. In general frameless modules are preferred in bifacial systems over framed one due to important self-shading of the modules in the early morning and later afternoon when the sun is close the horizon.

**PV plant failures**

Photovoltaic (PV) plant failures have a significant influence on PV plant security, reliability, and energy balance. Energy losses produced by a PV plant are due to two large causes: failures and inefficiencies. During the operation of PV system, failures can be found in the PV array such as snail trail, hot spot, diode failure, EVA discoloration, glass breakage, delamination with breaks in the ribbons and solder bonds, light induced degradation, low irradiance losses, potential induced degradation, shading effect, soiling effect, sun tracking system misalignments, wiring losses, and mismatching effect in solar array [109].

Some of these possible failures and risk of production losses have been categorised and assigned to stages in the project life cycle of a PV system, see [Figure 12](#) [Figure 9](#).

A. MODULES	B. INVERTERS
<b>Product testing / development</b>	
<ul style="list-style-type: none"> <li>• Failed insulation test</li> <li>• Incorrect cell soldering</li> <li>• Undersized bypass diode</li> <li>• Junction box adhesion</li> <li>• Etc.</li> </ul>	<ul style="list-style-type: none"> <li>• Inverter derating issue</li> <li>• Maximum power point tracker issue</li> </ul>
<b>PV plant planning / development</b>	
<ul style="list-style-type: none"> <li>• Soiling losses</li> <li>• Shadow diagram issue</li> <li>• Modules' mismatch</li> <li>• Uncertified modules</li> <li>• Etc.</li> </ul>	<ul style="list-style-type: none"> <li>• Inverter wrongly sized</li> <li>• Incorrect IP rating</li> <li>• Inverter cabinet inadequately ventilated</li> <li>• Inverter exposed to sunlight</li> <li>• Etc.</li> </ul>
<b>Transportation / installation</b>	
<ul style="list-style-type: none"> <li>• Module mishandling (Glass breakage)</li> <li>• Module mishandling (Cell breakage)</li> <li>• Module mishandling (Defective backsheet)</li> <li>• Etc.</li> </ul>	<ul style="list-style-type: none"> <li>• Inverter configuration incorrect</li> <li>• Missing contact protection</li> <li>• Inverter has no surge protection</li> <li>• Etc.</li> </ul>
<b>Operation / maintenance</b>	
<ul style="list-style-type: none"> <li>• Improperly installed</li> <li>• Hotspot</li> <li>• Delamination</li> <li>• Glass breakage</li> <li>• Snail trails</li> <li>• Etc.</li> </ul>	<ul style="list-style-type: none"> <li>• Fan failure and overheating</li> <li>• Theft or vandalism</li> <li>• Grounding fault</li> <li>• Firmware issue</li> <li>• Etc.</li> </ul>
<b>Decommissioning</b>	
<ul style="list-style-type: none"> <li>• No product recycling procedure defined or implemented</li> </ul>	<ul style="list-style-type: none"> <li>• Inverter size and weight issue</li> </ul>

Figure 12. Example of Risk Matrix for PV modules and inverters. Source: Solar bankability, 2017

The impact of energy loss due to inefficiencies or system derating factors are estimated to be between 22 to 28% that is higher than the energy loss due to failure, which is estimated to be lower than 1%. Monitoring on the DC side is not so critical, instead the focus should be on the inverter, transformer and the AC grid side. On the PV module side, the source of failures are module, DC wiring and junction box that accounts for a very small percentage of total failure rates. Furthermore, the PV plant is connected to the AC grid, presenting the possibility of [curtailment of generation](#), shutdown and

overvoltage, transformer failure, electrical setting protection failure and overheating due to overcurrent.

The main failure causes of PV inverters in terms of power electronics are either the power semiconductors or the capacitors. In the future, a priority should be to ensure that either the reliability of these two components is increased or the power electronics is empowered to make intelligent decisions about state of health of the inverter or these components [110].

The modules themselves can incur damage during transportation and handling at the site where they will be deployed:

- Damaged wiring
- Glass breakage
- Cell breakage
- Backpane damage

PV module failures also depend upon the climatic condition where a defective bypass diode is highest in hot and dry climate. Similarly, cell cracks are higher in cold and snowy climate in comparison to moderate climate and hot climate [104].

#### **4.1.5.3 PV system monitoring**

High quality Operation and Maintenance (O&M) services, when well-managed, reduce the LCOE of PV plants and thus positively impact the return on investment over the entire lifecycle. Best operations and maintenance practices, and related training of the technical staff have been listed in Task 3. Complementary, this section focuses on current and emerging technical solutions for O&M.

##### ***PV system yield monitoring***

There are two approaches in monitoring, a comparative approach (peer-to-peer monitoring) or performance metric monitoring when weather sensors are available. This latter approach is used for commercial and utility scale system. Its basis is the energy yield monitoring, typically on plant and/or string level, correlated with on site or satellite weather data input to detect under-performance. The monitoring of different parameters at plant level is required for the calculation of different key performance indicators (KPIs). This basic monitoring system provided irradiance, energy and performance ratio at plant level and, in case of malfunctioning, will trigger an alarm.

The most common key performance indicator is the performance ratio (PR) that normalizes the system output compared to measured insolation and DC system capacity at standard test conditions (STC) following IEC 61724. More advanced metrics such as a weather-corrected performance ratio or performance index have been proposed<sup>35</sup>.

The Standard IEC 61724-1(2017) defines three classes of PV monitoring systems that are summarized in [Table 8](#). For the smaller string inverters discussed in 4.1.4 it is possible to include part of a class C monitoring system in the inverter. A class C system requires the AC energy output, the in plane irradiance and the on-site ambient temperature to be recorded with 1 minute time interval. Irradiance and temperature do not need to be measured on site. Monitoring features that are not required by class C, but may also be useful and that can be easily incorporated in inverters are:

- Internet connection
- Power (PAC) and temperature read out of the inverter
- Logging of insulation errors detected RCD/IMD

<sup>35</sup> Joshua Stein; Mike Green; Novel strategies for PV system monitoring; PVtech Power; Vol 2., 2015



- Logging of grid frequency, anti-islanding, over-voltage and undervoltage alarms
- Vpv/Ipv present voltage and current of the PV string
- Logging of daily maximum power (PAC) combined with monitoring the maximum string voltage (this can indicate a wrong sizing of the inverter voltage versus string and/or a failed PV module)
- Operating hours

It is also possible to add the monitoring system as a separate system components<sup>36</sup>. This is a more common practice in larger systems, for which it can be more useful, as it was discussed in section 4.1.4.1. Adding more features, more accuracy and sensors can finally result in a class A system which can be considered as a candidate for BAT for large central inverters.

Typical applications	Class A High accuracy	Class B Medium accuracy	Class C Basic accuracy
Basic system performance assessment	X	X	X
Documentation of a performance guarantee	X	X	
System losses analysis	X	X	
Electricity network interaction assessment	X		
Fault localization	X		
PV technology assessment	X		
Precise PV system degradation measurement	X		

Table 89 PV monitoring system classifications and suggested applications (source: IEC 61724-1:2017)

More advanced monitoring platforms include lower granularity performance monitoring, numerous customised KPIs and fault analysis tools. For example string level monitoring (also critical for systems with different module orientations) and module-scale monitoring solutions are appearing on the market. Additionally tools for monitoring the health of the DC circuit by detecting alterations in the series resistance of the system exist, e.g. detecting cable corrosion which otherwise would be only detected upon catastrophic failure.

More advanced inverter monitoring solutions are proposed by numerous companies. Applying these solutions enable the early fault detection (before major power loss) and provide insights in the potential origin of the failure mode and its location. Several solution providers also make high-level recommendations to the site owner and guide technical operation and maintenance staff<sup>37</sup>. Besides production monitoring the PV plant owners often request a visual inspection tool to gather further information on the status of its PV plant, e.g. IR imaging based aerial inspection.

Monitoring solution providers often provide the owner with access to the database of the historic performance, logging of inverter faults, and previous interventions which provide an important foundation for valuation of PV plants. Most utility scale PV plants use a Supervisory Control and Data Acquisition (SCADA) system. The hardware backbone of such a system is a programmable logic controller (PLC) or a similar type of smart relay. . Alternatively the high-speed internet has enabled the development of web-based solutions either integrated with hardware solution or hardware diagnostic platforms.

Note that monitoring can support maintenance practices (see Task3) to extend the maintenance periods as long as everything is reported normal. However it cannot replace them all (e.g. visual inspection, cleaning modules and sensors, general house-keeping such as pruning trees, tightening bolts, calibrating sensors, etc.). Among the

<sup>36</sup> <https://shop.solar-log.com/en/equipment/?p=2>

<sup>37</sup> 3E, Health Scan

O&M contracts surveyed reported in an IEA PVPS study [104], annual frequency was the most common time frame contracted for preventative maintenance frequency.

### **Field inspection for fault diagnosis**

#### **Infrared imaging**

Recent research<sup>38</sup> and increasing feedback from the field experience,<sup>39</sup> has established infrared (IR) imaging as a very efficient and reliable tool for detailed inspection and advanced diagnostics of PV plants. Indeed, these efforts have demonstrated the applicability of IR imaging to detect different (electrical, optical, thermal) failures on PV system, module and cell level. They have also validated methodologies to diagnose and classify most of these failure modes from certain IR patterns (i.e. thermal signatures). Regular IR inspection could therefore be a candidate for BAT for commercial and utility scale PV plants.

As a result of broad deployment, IR-based diagnostics in the PV field has nowadays become streamlined and standardized, particularly through the work of technology collaboration platforms<sup>40</sup> and the release of IEC technical specifications<sup>41,42</sup>. Numerous pioneering service providers of aerial IR imaging for PV plants<sup>43,44,45</sup>, are active in the EU.

#### **Flash testing and electroluminescence on the field**

The use of complementary characterization techniques such as flash testing and electroluminescence imaging on the field can provide valuable information about fault diagnosis. Companies offering these services are just emerging and exact standard on their application on the field are not yet available. We consider these techniques could potentially be candidate as BNAT in the field of O&M.

#### **4.1.5.4 Additional system components**

##### **Solar Trackers**

For ground mounted systems solar tracking structures can be installed and they can boost the annual output up to 50 % [1] Such structures orient the modules better to the sun depending on the season and/or time of the day. These structures can move around one or two axis and the impact on yield can easily be calculated per location<sup>46</sup>.

Single axis trackers follow the movement of the sun from east to west, potentially increasing yields by up to 25%, while two axis tracking solutions allow to consider the seasonal variations and can increase yield by 35%<sup>47</sup>. The current split market share of single axis vs. dual axis has been estimated as being 65% and 35%, respectively but it is changing dynamically with dual axis trackers loosing market share due to their complexity<sup>48</sup>. The exact energy yield gain depends on geographical location, types of trackers used, module temperature coefficients, since the module operating temperature increases with the light level and exposure time. Some studies have identified the potential for significant divergence between simulated and real yield gains from tracking systems, suggesting that careful attention is needed to the validation the results that simulation softwares can provide.

<sup>38</sup> J. A. Tsanakas et al. (2016), Renew Sustain Energy Rev 62: 695–709.

<sup>39</sup> P.B. Quater et al. (2014), IEEE J Photovoltaics 2014.

<sup>40</sup> U. Jahn et al. (2018), Report IEA-PVPS T13-10:2018.

<sup>41</sup> IEC/TS 62446-3:2017.

<sup>42</sup> IEC/TS 60904-12 (draft).

<sup>43</sup> Heliolytics Inc. [<http://www.heliolytics.com/>]

<sup>44</sup> Sitemark (f.k.a. DroneGrid) [<https://www.sitemark.com/>]

<sup>45</sup> Above Surveying [<http://www.abovesurveying.com/>]

<sup>46</sup> <http://re.jrc.ec.europa.eu/pvgis.html>.

<sup>47</sup> PV Tracker System Net Gain Associated to the Local Climatic Conditions, C. Cabo Landeira, Á. López-Agüera, International Journal for Research in Applied Science & Engineering Technology Volume 6 Issue I, January 2018

<sup>48</sup> GLOBE NEWSWIRE, 2017

Formatted: French(France)

Formatted: French(France)

Formatted: French(France)

Formatted: Indent: Left: 0 cm, First line: 0 cm

Formatted: Indent: Left: 0 cm, Hanging: 0.25 cm

Tracking systems require more area to avoid row to row shading and therefore can be considered as an improvement option for large ground mounted systems with central inverter. During the system design the energy yield gain calculation should balance these elements with the increased installation and maintenance cost.

The tracker market is currently adapting to bifacial modules with adapted structural design to minimize rear shading and tailored tracking algorithms. To maximize light harvesting in bifacial systems the conditions of the sky and diffuse radiation must be considered by the tracker algorithm. Compared to monofacial tracking, unfocusing the tracker to favour backside production could be interesting in specific weather conditions<sup>49, 50</sup>.

Of all the components of a system it is understood that trackers have the greatest potential for failure. The associated downtime and loss of efficiency has to be factored in the calculations.

### Cabling

For photovoltaic installations wires with a sufficient Cross-sectional Area (CSA) are needed to avoid cable losses. This issue was already extensively examined in a separate Ecodesign study (Lot 8) on Power Cables [115]. The main recommendations of the study related to the application of the relevant standards relative to energy efficiency in electrical installations. Therefore it is suggested to re-examine this issue and to reconsider the proposed policy options.— In the case of PV installations, the following have been identified:

Maximum voltage drop prescribed by IEC 60364-7-712 - Low Voltage Electrical Installations - Part 7-712: It is recommended that under maximum load conditions the voltage drop from the most remote module in the array to the input terminals of the application circuit should not exceed 3 % of the PV array voltage at its maximum power point. This will impact cable sizing.

Economic cable sizing as defined in IEC 60287-3-2 - Electric cables - Calculation of the current rating - Part 3-2: Sections on operating conditions - Economic optimization of power cable size. This methodology is the one recommended by IEC 60364-8-1: Low-voltage electrical installations - Part 8-1: Energy efficiency.

Environmental Conductor Size Optimisation (ECSO) as defined in IEC CD 60125 Environmental considerations specific to insulated electrical power and control cables. Environmental and energy cost based Conductor Size Optimization (ECSO) is taking into account the cable's life phases' costs and reduction in power loss costs during use phase and related costs of CO2 compared to the conventional sizing of highly loaded cables with significant energy losses. ECSO takes specifically into account:

- The initial cost of investment including manufacturing, transportation, installation and final disposal costs;
- Cost for CO2 emission during manufacturing, transportation and installation and final disposal;
- Costs for Joule losses during anticipated lifetime;
- Costs for CO2 emission during the anticipated lifetime.

Temperature correction factor. The following references are relevant:

- EN 50618 Electric Cables for photovoltaic systems. The electrical resistance of each conductor at 20°C shall be in accordance with the requirements of EN 60228 for a metal coated Class 5 conductor. Also, this standard provides the appropriate

**Formatted:** Bulleted+ Level:1 +  
Alignedat: 0.63 cm + Indentat: 1.27  
cm

**Formatted:** Bulleted+ Level:1 +  
Alignedat: 0.63 cm + Indentat: 1.27  
cm

<sup>49</sup> J. Guerrero, Both sides of the story, Pv Tech Power, vol 16, 2018

<sup>50</sup> Vokas et al., Single and dual axis PV energy production over Greece: Comparison between measured and predicted data, Energy Procedia, 2015

figures for the current carrying capacity of PV cables and the current rating conversion factors for different ambient temperatures. See attachment with TÜVRheinland PV cable approval example according to EN 50618.

- IEC 60364-7-712 - Low Voltage Electrical Installations - Part 7-712: Requirements For Special Installations Or Locations - Solar Photovoltaic (PV) Power Supply Systems. A PV array's performance may be affected by many factors, including but not limited to temperature rise. Cables used within the PV array shall:

*Have a temperature rating according to the application, taking into account that PV modules frequently operate at temperatures of the order of 40°C above ambient temperature and therefore cable insulation of wiring installed in contact or near PV modules shall be rated accordingly;*

Formatted: Font: Italic

Formatted: Indent: Left: 1.27 cm, Firstline: 1.27 cm

The ambient temperature for cables subjected to direct heating from the underside of PV modules shall be considered to be at least 70°C.

These options could be of particular relevance to any potential Green Public Procurement (GPP) criteria for systems.

#### **4.1.5.5 Dismantling PV systems at the end of life**

PV systems and their components fall within the scope of the WEEE recycling, see section 4.2. Particular issues at system level that require consideration relate to the ability to dismantle and return the components for reuse or recycling.

While dismantling and returning PV components from larger systems installed in open field or on flat roofs may be considered more straightforward, this type of dismantling work can be more complex, cumbersome and relatively expensive for multiple smaller residential Building Attached PV (BAPV systems). This is in part due to the costs of gaining access to roofs.

Note that apart from dismantling at end of life also a building catching fire is a possible end of life scenario that could warrant further attention within the frame of this study.

For **smaller systems two relevant improvement options are to consider halogen free cables and backsheets**. This can be beneficial to avoid harmful halogen smoke during incineration at the end of life or when a building takes fire.

#### **4.1.5.6 Summary of improvement options and impact on Performance, Bill of Material and product price**

In summary based on the previous sections the following base cases (BC) and possible combinations of design improvements have been identified at the system level (see Table 8, Table 9 and Table 10). These comprise:

- The 'Base Case' (BC) as an average system wherein:
  - BC 1: is a 2.5 kW residential PV system
  - BC 2: is a 20 kW commercial PV system
  - BC 3: is a large central inverter ~~above 100~~ 1.5MkW
- The following improvement options have been identified as potential candidates for BAT:
  - To change from an 'average' designed system to the best available (see also Task 3), referred as BC-des.

- To change from an 'average' monitored and designed system to the best available (Class C monitoring + options for BC1, Class B monitoring for BC 1, Class A for BC 1), referred as BC-mon.
- To change to a halogen solution in BC 1 (see also Task 3), referred as BC-F-free.
- To add solar trackers to utility scale PV systems, referred to as 'BC-track'

Table 930 System level improvement options for a residential PV system

	<b>BC 1</b>	<b>BC 1-des</b>	<b>BC 1-mon</b>	<b>BC 1- F free</b>
Type	Small residential Default installation	Small residential Optimised design and yield forecasting	Small residential Optimised monitoring and maintenance	Small residential halogen free cables
Predicted yield	100 %	+5 %	+5 %	+0%
PR	0.75	0.80	0.85	0.75
Cost	100 %	+5 %	+10%	TBD
Bill of Material	Standard	Standard	Standard	Halogen free cables

Table 1014 System level improvement options for a medium size commercial PV system

	<b>BC 2</b>	<b>BC 2-des</b>	<b>BC 2-mon</b>
Type	Medium commercial Default installation	Medium commercial Optimised design and yield forecasting	Medium commercial Optimised monitoring and maintenance
Predicted yield	100 %	+5 %	+5 %
PR	0.75	0.80	0.85
Cost	0	+ 20 €/kW <sup>1</sup>	+4€/kW+10% <sup>1</sup>
<u>Bill of Material</u>	<u>Standard</u>	<u>Halogen free cables</u>	<u>Halogen free cables</u>
1. Best practice guidelines for PV cost calculations. Solar bankability, 2016			

Formatted Table

Table 1112 System level improvement options for a large utility scale system

	BC 3	BC3-des	BC3-mon	BC3-track
Type	Utility scale Default installation	Utility scale Optimised design and yield forecasting	Utility scale Optimised monitoring and maintenance	Utility scale With <del> dual</del> <u> single</u> axis trackers
Predicted yield	100 %	<del>+5 %</del> <u>Already standard practice</u>	<del>Already standard practice</del> <u>+5 %</u>	<del>+10</del> <u>25</u> % ( <del>can be</del> calculated, depends on location)
PR	0.75	0.80	0.85	0.75
Cost	0	+ 20 €/kW <sup>1</sup>	+4€/kW+10% <sup>1</sup>	TBD

1. Best practice guidelines for PV cost calculations. Solar bankability, 2016

#### 4.1.6 BIPV module and system

##### 4.1.6.1 Standard product scope: performance

The term building integrated photovoltaics (BIPV) refers to multifunctional building elements which use the sunlight to generate electricity, on the basis of solar cells technology. In other words, BIPV systems comprise photovoltaic components that also serve multiple building and architectural functions, similarly to conventional elements of the building envelope (i.e. façades and/or roofs). Thus, BIPV are defined both in functional terms (in line with the European Construction Product Regulation CPR n.305/2011) and in aesthetical terms, as an architectural concept [116]. Such required "multifunctionality" of BIPV relates to integral **performance properties**, i.e. thermal and electrical insulation, water and air tightness, acoustics (soundproofing), induced thermal comfort and ventilation, aesthetics and impact on visual comfort (daylighting/shading, colour, texture), energy economy and recyclability.

Two main BIPV segments can be identified, based on their application area: roofs and façades. Most BIPV technologies that are widely available in the market today come from the former segment. Solar tiles in particular (also including variations, such as shingles and slates) are the BIPV product with the leading share in the market (24%), followed by full roof solutions (15%). In terms of the PV technology used, crystalline silicon (c-Si) based solutions represent the most dominant, by far, product for roof BIPV applications, corresponding to 72% of the relevant market [117].



Figure 134: Examples of small-sized (upper right/left images) and large-sized (lower right/left images) BIPV solar tiles [25].

Focusing further on the most common roof BIPV product, solar tiles are in principle classified in terms of size (Figure 13Figure-4) [118]:

- Small ( $\leq 0.5 \text{ m}^2$ , typically  $0.4 \times 0.6 \text{ m}^2$ ); a few solar cells encapsulated in a PV laminate, within structures (composed of several materials, e.g. plastic, clay) resembling traditional construction products.
- Large ( $> 0.5 \text{ m}^2$ , typically  $0.6 \times 1.5 \text{ m}^2$ ); more complex systems/structures that include building elements and interconnections, 2-4 times wider than traditional tiles (or shingles or slates), mostly based on glass or foil. Such systems usually allow for full roof-filling. Typical weights:  $13\text{-}20 \text{ kg/m}^2$ .

In both groups of solar tiles, the electrical efficiency and power output per area are generally lower than in standard PV modules.

The leading BIPV roofing products in the market today come with power output in the range of 9 to 60 W per unit, for small-sized solar tile products; and in the range of 86 to 150 W, for large-sized ones<sup>51</sup>. Small solar tiles are considered advantageous for optimized roof filling and aesthetics, while larger tiles come with the potential of lower price per area unit. Solar tiles can be either glazed (glass sub/superstrate) or foil-based on i.e. polymer membranes or coatings [116]. Normalized power outputs for both size groups are rather varying, in the range of 80.1 up to  $184.2 \text{ W/m}^2$ . Besides, the electrical efficiency of such solar tiles ranges from 13.9% to 15.9%, values which are significantly lower – as aforementioned – when compared to standard PV modules.

In the façades segment, rain-screen (“cold”) façades and skylight/solar glazing solutions are the most widespread products. Rain-screen façade systems typically consist of a load-bearing sub-frame, an air gap and a cladding panel. On the other hand, glazed PV laminates for skylight/solar glazing applications are made either by c-Si cells with adjusted spacing or by laser grooved thin films which provide filtered vision, encapsulated within glazed panes. Notably, 44% of commercially available BIPV façade solutions are based on thin films technology. The advantages of superior aesthetic appearance and lower cost per area unit are the main drivers for such a relatively large share of thin films among BIPV façades [118].

Depending on the unit size, rain-screen PV façade products have power output which ranges from 33 to 125 W for thin film based products; and from 40 to 310 W, for c-Si

<sup>51</sup> Solarcentury C21e series (UK), ZEP Zonneceldakpannen (Netherlands), SunTegra™ Solar Shingles & Tiles (USA), Sun Net Solcelletaktegl (Norway/Germany), Heda Solar PV module/tile (China), Romag Intecto Solar Roof Tiles (UK)

based ones<sup>52</sup>. In the skylight/solar glazing products group, available solutions in the market come with a power output from 44 to 55 W for thin film based skylights; and from 80 up to 380 W for c-Si based ones<sup>53</sup>. As in the case of solar tiles, normalised power outputs for both two BIPV façade types are in the range of 100 up to 186 W/m<sup>2</sup>, while the electrical efficiency of such products varies from a relative low 11.2%-12.8% (for thin film based ones) up to 18% (for solutions based on standard glass-glass c-Si PV modules).

#### **4.1.6.2 Extended product scope: energy generation potential and reliability (incl. warranty/product claims)**

##### **BIPV reliability and performance considerations**

In BIPV systems, the particularity of the full integration and operation of PV modules within the buildings' envelope lead to considerably higher operating temperatures. Various strategies are being investigated to reduce the PV temperature of BIPV façade/roof systems.

- *Metal fins/heat sink*: In this option, metal fins are attached on the back side of the PV modules, working as heat sinks to cool the [panel module](#). The effectiveness of this low-cost solution was investigated through an experimental pilot. This type of BIPV façade system was built and tested in Eurac<sup>54</sup>. Application of fins could be considered as a "passive-low cost" strategy to slightly improve the performance of a BIPV façade system.
- *Phase change materials (PCM)*: Using PCMs for temperature regulation and temporary heat storage in photovoltaic/thermal systems (PVT) is an emerging technology that has attracted attention recently. The PCM absorbs heat and regulates peak temperature, which allows the PV [panel module](#) to operate at lower temperatures during peak solar conditions. Further, the waste heat stored in the PCM can be used for other applications.

Apart from PV degradation and failures due to high operating temperatures, mismatch losses due to shading and soiling can have substantially negative impact on the BIPV energy yield, especially for systems/buildings with certain architectural constraints and/or located in areas with adverse conditions (e.g. dust or snowfalls). Indeed, research activity has shown that mismatch losses are largely site-dependent [119]–[121], principally related to small-scale effects and location or building characteristics. Thus predicting, quantifying and mitigating losses due to soiling or shading remains a challenge. Standard PV financing models and simulation tools assume mismatch losses ≤2% of the annual energy yield. In principle, matching such a rate in BIPV installations, requires costly "smart" monitoring or distributed power electronics; and a range of other (often non-optimized, non-standardized) solutions for soiling and shading management and mitigation (e.g. manual or robotic cleaning). Indeed, module power electronics (DC optimizers or micro-inverters) are greatly beneficial boosting by up to 15% the energy yield of multi-string residential BIPV installations that are more prone to mismatch losses [122], [123].

##### **BIPV standardization aspects**

<sup>52</sup> Flisom AG, SF Gen1 (Switzerland), Hanergy Solibro CIGS (China), Scheuten Glas Optisol Skin (Netherlands), Solarwatt Vision (Germany)

<sup>53</sup> Asola Technologies GmbH VITRUM SunSecret (Germany), Ertex Solar VSG-EVO-Module (Austria), Galaxy Energy GmbH Galaxy Energy Indachsystem (Germany), Kaneka SEE-THROUGH (Belgium), Scheuten Glas Optisol Sky (Netherlands)

<sup>54</sup> EURAC, Bolzano (Italy)  
[<http://www.eurac.edu/en/research/technologies/renewableenergy/researchfields/Pages/Photovoltaic-systems.aspx>]



In the case that BIPV products form part of the building's envelope providing electrical energy, the requirements and test conditions from the building side following the EUROCODE come from CEN and ISO, while the electrical performance and safety rules come from CENELEC and IEC. The requirements for building construction materials and components are generically formulated, and hence tests are performed on specific test samples. The tests on PV modules are related to the very specific type and form of the modules, and changes in dimensions and components require subsequent retesting<sup>55</sup>.

There was an attempt from ISO technical committee Glass in Building TC 160 [120], to write a standard for glass/glass PV modules for building integration (draft ISO DIS 18178 Laminated solar PV glass). IEC TC82 started a new work item on proposals for PV building integration. In addition, at international level under the framework of the PVPS Technology Collaboration Programme of the International Energy Agency [120] there is also an active group working on PV building integration issues. Recently, these different approaches are bundled in the new Project Team PT 6309213, that is a collaboration based at IEC, open to members of ISO and the IEA PVPS. It was decided to take the European EN 50583:2016 BIPV Standard as a starting point for the future development of an international standard. The latter assigns application-specific requirements to PV modules – divided into the main categories; "containing-" and "not containing glass panes". It further differentiates between general requirements that have to be fulfilled by all products (electrical- and building-related requirements) and requirements that only have to be fulfilled depending on the constructional set-up (e.g. fire resistance classification acc. to EN 13501-1).

#### **Dismantling and recycling BIPV systems at the end of life**

PV systems and their components fall within the scope of the WEEE recycling, see 4.2. Particular issues at system level worth mentioning are related to the effort to dismantle and return the components for recycling. **Two relevant improvement options to consider are Pb-free and halogen-free modules.** This can be beneficial to avoid harmful halogen smoke if polymers are incinerated at the end of life or when a building catches fire. Also in BIPV the identification and sorting of Pb and halogen containing polymers can be more complex compared to standard solutions and therefore these two improvement options can be relatively more important.

## **4.2 Lifecycle analysis available data sources to model production for lifecycle analysis**

### **Aim:**

This section includes a compilation of data sources for the bill of materials (BOM), that would be modelled according with the revised ecodesign methodology (MEErP) and complemented, where relevant and feasible, with information from the Product Environmental Footprint (PEF) results.

### **4.2.1 Selected data sources and BOM**

#### **4.2.1.1 Modules –**

An updated bill of materials for multi-Si modules will be provided by the PV sector. Other possible sources of data are:

<sup>55</sup> At present the retesting guideline is a document from the international community of high quality test labs, CTL within the IECCE CBTL scheme agreed on, see <https://www.iecee.org/committees/ctl/documents/ctl-documents.htm>. An international IEC Guideline, is almost finished: IEC TS 62915 ED1: Photovoltaic (PV) modules - Retesting for type approval, design and safety qualification, expected in 2018.

Formatted: Indent: Left: 0 cm, First line: 0 cm

- Product Environmental Footprint screening study<sup>56</sup>: Data available for:
  - o Cadmium-telluride PV technology
  - o Copper-indium-selenium (CIS) PV technology
  - o Micromorphous Si PV technology
  - o Multicrystalline Si PV technology
  - o Monocrystalline Si PV technology
  - o Electric installation and mounting structure

—Ecoinvent<sup>57</sup>

—

—IEA PVPS task 12<sup>58</sup>

~~—Vellini et al. (2017)<sup>59</sup> published a LCI of a Si-panel and CdTe-panel in the paper 'Environmental impacts of PV technology throughout the life cycle: Importance of the end-of-life management for Si-panels and CdTe-panels'.~~

—

### Base case Multi Si

Data from the PEF screening study<sup>4256</sup> but will be updated by Mariska De Wild-Scholten, Greenscans.

The BOM in Eco report format is available in task 5.

### Recycling

- Life cycle inventory of recycling of photovoltaic modules is available in a publication from treeze Ltd. (Stolz et al., 2016<sup>60</sup>). This publication contains LCI data for the recycling of c-Si PV modules and the recycling of CdTe PV modules.

#### 4.2.1.2 Inverters

- Life cycle inventory of inverters is available in a publication from treeze Ltd.: (Tschümperlin et al. 2016). This publication contains LCI data for the manufacture and disposal of solar inverters of 2.5 kW, 5 kW, 10 kW and 20 kW.
- Bill of materials of photovoltaic inverters, sources of failures and life time issues are similar to Uninterruptable Power Supplies (ENER Lot 27), LED or fluorescent lamp drivers (ENER Lot 19) and motor drives (ENER Lot 30).

#### Base case String 1 phase – 2500 W

Data for the inverter have been taken from a publication from treeze (Tschümperlin et al. 2016)<sup>46</sup>.

<sup>56</sup> Wyss F., Frischknecht R., de Wild-Scholten M., Stolz P. 2015. PEF screening report of electricity from photovoltaic panels in the context of the EU Product Environmental Footprint Category Rules (PEFCR) Pilots

<sup>57</sup> Wernet, G., Bauer, C., Steubing, B., Reinhard, J., Moreno-Ruiz, E., and Weidema, B., 2016. The ecoinvent database version 3 (part I): overview and methodology. The International Journal of Life Cycle Assessment, [online] 21(9), pp.1218–1230. Available at: <http://link.springer.com/10.1007/s11367-016-1087-8>

<sup>58</sup> Frischknecht R., Itten R., Sinha P., de Wild-Scholten M., Zhang J., Fthenakis V., Kim H.C., Raugei M., Stucki M. 2015. Life Cycle Inventories and Life Cycle Assessment of Photovoltaic Systems, International Energy Agency (IEA) PVPS Task 12, Report T12-04:2015

~~<sup>59</sup> Vellini M., Gambini M., Prattella V. 2017. Environmental impacts of PV technology throughout the life cycle: Importance of the end-of-life management for Si-panels and CdTe-panels. Energy 138 (2017) 1099e1111~~

<sup>60</sup> Stolz P., Frischknecht R.. 2016. Life cycle assessment of photovoltaic module recycling. Available online: [http://treeze.ch/fileadmin/user\\_upload/downloads/Publications/Case\\_Studies/Energy/174-LCA-Recycling-PV-Modules-v1.1.1.pdf](http://treeze.ch/fileadmin/user_upload/downloads/Publications/Case_Studies/Energy/174-LCA-Recycling-PV-Modules-v1.1.1.pdf)

Formatted: Bulleted+ Level:1 +  
Alignedat: 0.63 cm + Indentat: 1.27  
cm

Formatted: Bulleted+ Level:1 +  
Alignedat: 0.63 cm + Indentat: 1.27  
cm

Formatted: Superscript

Field CodeChanged

Formatted: Font: Bold, Italic

Formatted: JRC\_Text

Formatted: Font: Verdana, 8 pt

Formatted: Font: Verdana

Formatted: Font: Verdana, English  
(U.S.)

Formatted: English (U.S.)

The BOM in Ecoreport format is available in task 5.

**Base case String 3 phase – 20 kW**

Data for the inverter have been taken from a publication from treeze (Tschümperlin et al. 2016)<sup>46</sup>.

The BOM in Ecoreport format is available in task 5.

**Base case Central inverter**

Consists of several 20 kW inverters. Can we extrapolate the BOM for 20 KW inverters to 1500 kW inverter? → 75 times 20 kW inverter?

Formatted: Font: Bold, Italic

Formatted: JRC\_Text

Formatted: Font: Bold, Italic

Formatted: Font: Bold, Italic

Formatted: JRC\_Text

**4.2.1.3 System level**

At system level the modelling will be based on the module characteristics described in Table 12 Table 11.

Table 12<sup>43</sup> Module characteristics

	Multi Si	Mono Si	CdTe
Module Size (m <sup>2</sup> /panel/module)	1.6	1.6	0.72
Panel/Module weight (unframed) (kg/m <sup>2</sup> )	11.2	11.7	17.1
Module conversion efficiency (%)	14.7	15.1	14.6
Wafer thickness (micrometer)	200	190	2.5
Cell size (mm <sup>2</sup> )	156*156	156*156	-
technology	Average technology mix of front/back cell connection, diffusion and front collection grid	Average technology mix of front/back cell connection, diffusion and front collection grid	
Main data source	De Wild-Scholten (2014)	De Wild-Scholten (2014)	First Solar (2014)
Rated power (Wp/m <sup>2</sup> )	147	151	145
Average annual yield (kWh/kW)	926.25	976	984.75
Degradation rate	0.7%	0.7%	1.0%
Failure rate	0.005-0.1% <sup>1</sup>	0.005-0.1% <sup>1</sup>	TBD
Module area per kWh produced (m <sup>2</sup> ) – 3 kWp installation	2.39E-04	2.34E-04	2.44E-04
1. Kurtz S. NREL, reliability and durability of PV modules in Photovoltaic Solar Energy: from fundamentals and applications, John Wiley and Sons, 2017			

Formatted: Superscript

The previous data sources do not necessary use the same units that are used in the MEERP, which is in mass per PV module. Based on some physical properties the typical Bill of Material data for silicon and front glass can be calculated. For example, for a typical multi Si module with 60 cells, see [Table 13](#)~~Table 12~~.

Table 13~~14~~ Extrapolated data from the PEF to a commercial PV module

PEF data	Multi Si - 3 kWp
Module Size (m <sup>2</sup> /module)	1.76
Module weight (unframed) (kg/m <sup>2</sup> )	11.72
Module conversion efficiency (%)	14.7
Wafer thickness (micrometer)	200
Cell size (mm <sup>2</sup> )	156*156
<b>link to commercial module</b>	
Area of module(m <sup>2</sup> )	1.76
Module power rating	235
Cells per module	60
Weight of cells (g/ m <sup>2</sup> )	558.7
Max. scrap value of silicon metal in module(euro)	0.67
Weight of Silicon on module(kg/module)	0.67
Silicon per m <sup>2</sup> (kg/m <sup>2</sup> )	0.42
Value of silicon metal in module(euro)	1.05
Total mass of module	17.79
% silicon in total mass module	3.77%
<b>link to cell data</b>	
shape of cells	Pseudosquare
Wp per cell (Wp)	3.768
Si Weight per cell (g)	11.713
<b>Frontglass</b>	
thickness (mm)	3.2
weight per m <sup>2</sup> (kg)	8
share in BOM (%)	71.74%

Formatted: Right

According to the IEA PVPS report on recent trends [104], there is a predictive maintenance practice wherein an inverter replacement is usually planned just after year 10 of the PV system operation. Therefore the inverter will be replaced 2 times in 30 years in the life span (at year 10 and at year 20).

For larger central inverter systems we will assume that the housing cabinet, connectors, distribution boxes will be kept because they won't wear out and this simplifies the replacement work. For larger rated systems the data can be upscaled in proportion to the rated power (kVA).

Batteries recycling will be discussed in another Ecodesign study on rechargeable electrochemical batteries: <https://ecodesignbatteries.eu/>

Field CodeChanged

### 4.3 Conclusions and recommendations

In this Task 4 of the Preparatory Study a range of technical improvements have been identified and analysed for:

- photovoltaic modules at wafer, cell and product level,
- inverters at product and component level, and
- systems in respect of design, operation and maintenance practices.

Based on this analysis base cases have been identified for the three products that form the scope of the Preparatory Study. –In order to facilitate the modelling of future improvement potential of each of the products, a range of design options have been selected that may be candidates to be either a Best Available Technology (BAT) or Best Not Yet Available Technology (BNAT) at product level. These design options will be included within the modelling in Task 6.

#### 4.3.1 Module design options

The base case for the reference year of 2016, as defined previously in Task 2, has been identified as a ~~polymulti~~silicon module based on ~~interdigitated~~ back contact cells also known as Back Surface Field (BSF) metallisation. –With a cell efficiency of 14.7% this technology accounted for the majority (more than 70%) of module products on the market at the time.

~~Although a thorough analysis is carried out in Task 6 to determine it, t~~The possible candidates for the Best Available Technology (BAT) at module and cell level are CIGS and CdTe thin films, as well as modules consisting of PERC/PERT, back contact, heterojunction and bifacial crystalline silicon cell designs. ~~Despite-Although~~ the cell efficiency and degradation rate of CIGS and CdTe appears to be inferior to the crystalline silicon cell technologies identified ~~–;~~ initial evidence suggests that their life cycle performance for the functional unit of 1 kWh ~~–~~ may be superior.

Traditionally the focus of attention for module design options has been on efficiency, the highest efficiency products in the market are PERC/PERT, HTJ and backcontact on monocrystalline wafers. However measurements of efficiency under standard conditions do not take into account all of the performance parameters in the field. Thin film and HTJ products demonstrate improved performance under certain conditions in the field. An energy rating according to IEC 61583-3 would take into account other parameters such as temperature coefficients, low-light/irradiance performance, incidence angle, etc. thereby capturing improvements on performance under a broader set of real life conditions.

Additional module design options that could be combined with these cell designs primarily relate to interconnections, encapsulation and backsheets :

- Interconnections: the eElectrical efficiency of crystalline technologies can be improved by using thinner busbars, multi wire design or –electro-conductive backsheets to eliminate busbars – and the use of half cells. A trade-off exists between some of these options in which the use of silver can be reduced whilst more lead must be introduced into solder compounds and metallisation paste. Lead-free compounds are understood to have been demonstrated at commercial-scale but more information is required on their durability and the extent of their application field.
- Encapsulation: In relation to encapsulation, material selection can contribute to the reduction of water ingress and permeation, which in the field evidence suggest can resulting in subsequent chemical reactions that can result incontribute to material and performance degradation. Material selection can also improve resistance to UV degradation. These material options may therefore improve module performance and durability along the lifetime. Glass-glass encapsulation could also minimise the potential for breakage of cells but would introduce a trade off in terms of material impacts - due to the greater environmental burden of glass.

- Backsheet: Material selection can influence the durability, [recyclability](#) and water permeability of a module. The fire protection properties must also be taken into consideration and in this respect there appears to be a trade-off between cost, durability and the potential need for flame retardants – although more information is needed about the latter.

Opportunities also exist to reduce failure and performance degradation mechanisms at a number of stages in the process of bringing a product to market. These include, in addition to those already noted in relation to encapsulants, the potential at the following stages:

- Product design stage: Implement accelerated life testing routines that combine environmental testing in order to provide feedback to the design and material selection processes. This may result in multiple improvements rather than a single identifiable design option.
- Manufacturing stage: Minimise manufacturing defects by implementing a series of factory quality testing and inspection routines;
- Transport stage: Minimise transport damage by considering the packaging used to ship products and to distribute modules to installation sites;
- Use stage: Ensure that bypass diodes can be accessed and readily exchanged in order to minimise total or partial power loss.

Whilst warranted product performance providing extended coverage of manufacturing defects and more stable long term efficiency is currently offered by some manufacturers, these have limited validation based on standardised product testing and performance in the field. This is particularly the case for PERC/PERT and bifacial cells, which have had limited deployment in the field. Proxies for improved performance could include accelerate life testing with multiple stress factors applied to a single product.

Candidates for the Best Not Yet Available Technology (BNAT) include modules consisting of crystalline silicon cells created by lift-off or epitaxial growth – thereby reducing silicon waste - or where the crystalline silicon cell is in a tandem formation with perovskite thin films – offering a further improvement in cell efficiency. [Design for dismantling and ease of disassembly for repairing are currently considered to be BNAT practices given the limited examples of products. In the short term modules could include marking of the materials content in order to facilitate sorting and recycling, and in some to identify the presence of specific materials and chemistries that may hinder the recycling process.](#)

#### 4.3.2 Inverter design options

The base cases for the reference year of 2016, as defined previously in Task 2, have been identified according to their application field – 1 string inverter (residential segment), 3 string inverter (commercial segment) and central inverter (utility scale segment). The Euroefficiency of the base cases will be set at a level that accounts for the majority (of inverter products on the market at the time in the relevant application field. A performance of 97.5% is proposed as a base case euroefficiency.

In addition to this efficiency, Maximum Power Point Tracking (MPPT) is an important variable. This value is also proposed to be defined within the base case.

[Although a thorough analysis is carried out in Task 6 to determine it, the possible candidates for the Best Available Technology \(BAT\) include:](#)

- Micro-inverters, which offer benefits at system level because of their module-level Maximum Power Point Tracking (MPPT) and warranted reliability that is intended to match the 25 year+ lifespan of modules. Validation of the extended warranty periods being offered based on lifetime testing and feedback from the field would, however, be required in order to support BAT status;

- Inverters that incorporate wide band gap metal-oxide-semiconductor field-effect transistors (MOSFET) which are able to maintain high performance at higher operating temperatures. They also allow for a reduction in the bill of materials although the possible trade-off in terms of the impacts of manufacturing the distinct electronic components requires further analysis.

Whilst it is understood that central inverters are commonly repaired and their primary components replaced during their relatively long lifespan (20-30 years), more information is needed on the potential for other inverter types on the potential for repair and replacement of components identified as the common cause of failures – namely main circuit board, AC contactors, fuses, capacitors and fans. It appears that water ingress and high operating temperatures may be key causes of failures.

The main candidates for the Best Not Yet Available Technology (BNAT) are inverter designs based on wider band gap semi-conductors (MOSFET). Whilst some products are understood to have entered the market in 2018 – suggesting that they could eventually be candidates for BAT - more information is needed on their commercialisation status.

The complementary role of optimisers installed at module-level in providing the function of Maximum Power Point Tracking (MPPT) can also be highlighted.

#### 4.3.3 Photovoltaic system design options

The system base cases are proposed as consisting of representative systems for the market segments of residential (3 kW), commercial (20 kW) and utility scale (1.5 MW). These three segments are considered representative of the system scales, electrical configurations and siting conditions that are tracked by market intelligence, the IEA PVPS programme and as the basis for analysis of system cost and performance.

In order to ensure comparability it is proposed as a starting point that each base case incorporates the same module product – based on multi-crystalline aluminium back surface field cells – and only system-level performance improvements are then introduced as the basis for modelling. Later packages of module and inverter combinations could be introduced, selected based on the outcomes of the BAT and LLCC analysis.

Although a thorough analysis is carried out in Task 6 to determine it, the possible candidates for system-level BAT focus are mainly on the potential to transfer optimised performance improvement practices from the utility scale segment to the residential and commercial segment where equipment selection, Performance Ratios and maintenance routines are typically less optimised. This could initially include the energy rating of modules under more representative conditions, more reliable/repairable inverters which are also smart-enabled to support monitoring, the minimisation of module mismatch and cabling losses.

The focus for system design improvements should extend to then support operation & maintenance practices. This should be with a focus on optimising energy yield by addressing derating factors such as soiling, and by diagnosing failures in the inverters and on the AC side. The two main improvement options that have been identified are as follows:

- Optimised design and yield forecasting: The use of more dynamic simulation yield modelling and forecasting software with a higher probability of accuracy (e.g. P90 exceedance level). This could include installation of a class C monitoring system on inverters to later monitor the yield with a high granularity.
- Optimised monitoring and maintenance: The potential to follow-up module and inverter failure identification with the repair of key components should be addressed. The use of remote field inspection in order to make fault diagnosis is also a possibility. This could include the application of IR imaging across multiple residential systems.

In terms of system components, the installation of bifacial modules in combination with the treatment of roof surfaces to improve reflectance, as well as the incorporation of single axis trackers to improve yield are proposed.

An additional option for system modelling is the inclusion of battery electrical storage. This is not yet considered to be a potential BAT as the environmental benefits have not yet been analysed in detail.

For the end of life the decommissioning plan is becoming a requirement for large systems and facilities and processes are now being developed to handle modules as waste arising increase into the future. The state of the art is represented by a mechanical dismantling and in some cases via chemical processing of the semiconductor. More information is needed on the inverter end of life routes.



## References

- [1] S. H. Antoine Luque, *Handbook of Photovoltaic Science and Engineering*. 2011.
- [2] Fraunhofer ISE, "Photovoltaics Report," (updated 27 August 2018), 2018.
- [3] A. Goodrich *et al.*, "A wafer-based monocrystalline silicon photovoltaics road map: Utilizing known technology improvement opportunities for further reductions in manufacturing costs," *Sol. Energy Mater. Sol. Cells*, vol. 114, pp. 110–135, Jul. 2013.
- [4] REC, "REC Silicon's fluidized bed reactor (FBR) process." <http://www.recsilicon.com/technology/rec-silicons-fluidized-bed-reactor-process>.
- [5] C. W. Lan *et al.*, "The emergence of high-performance multi-crystalline silicon in photovoltaics," *J. Cryst. Growth*, vol. 468, pp. 17–23, Jun. 2017.
- [6] ITRPV, "International Technology Roadmap for Photovoltaic - Results 2017 including maturity report 2018," no. September, p. 4, 2018.
- [7] P. J. Verlinden *et al.*, "Challenges and Opportunities of High-Performance Solar Cells and PV Modules in Large Volume Production," [Plenary Talk in Session Area 9: "PV Modules, Manufacturing, Systems and Applications", The 42nd IEEE PVSC, New Orleans \(LA\), USA, 2015.](#)
- [8] <https://www.infineon.com/cms/en/about-infineon/press/press-releases/2018/INFXX201811-016.html> "Silteetra website."
- [9] H. S. Radhakrishnan, V. Depauw, K. Van Nieuwenhuysen, I. Gordon, and J. Poortmans, "Epitaxial Si lift-off technology: Current status and challenges," *Photovoltaics Int.*, vol. 38, no. September, pp. 44–56, 2017.
- [10] [NexWafe™ GmbH, Kerfless Wafer Technology. Available at: https://www.nexwafe.com/#technology](https://www.nexwafe.com/#technology) "NexWafe website."
- [11] K. Komoto and J.-S. Lee, *End-of-Life Management of Photovoltaic Panels: Trends in PV Module Recycling Technologies. Report IEA-PVPS T12-10:2018*. 2018.
- [12] S. Kang, S. Yoo, J. Lee, B. Boo, and H. Ryu, "Experimental investigations for recycling of silicon and glass from waste photovoltaic modules," *Renew. Energy*, vol. 47, pp. 152–159, 2012.
- [13] H. Knut Sander, Sarah Julie Otto, Lisa Rödig, Lukas Wagner Ökopol GmbH, "Behandlung von Elektroaltgeräten (EAG) unter Ressourcen- und Schadstoffaspekten," 2018.
- [14] K. Liu, "China Silicon Metal Overview and Prospect," *16th Annu. Ferro-alloys Conf.*, 2015.
- [15] United States Geological Survey, "2016 Minerals Yearbook - Silicon," no. August, 2016.
- [16] F. Mathieux *et al.*, *Critical raw materials and the circular economy - Background report*, no. December. 2017.
- [17] J. Götze and R. Möckel, "Quartz: Deposits, mineralogy and analytics," *Quartz Depos. Mineral. Anal.*, pp. 1–360, 2012.
- [18] M. Di Sabatino, F. W. Thorsen, A. Lanterne, Y. Hu, J. A. Bones, and E. Øvrelid, "Investigation on quartz crucibles for monocrystalline silicon ingots for solar cells," *Miner. Met. Mater. Ser.*, no. 9783319521916, pp. 387–394, 2017.
- [19] M. A. Green, "The Passivated Emitter and Rear Cell (PERC): From conception to mass production," *Sol. Energy Mater. Sol. Cells*, vol. 143, pp. 190–197, Dec. 2015.
- [20] T. Dullweber and J. Schmidt, "Industrial Silicon Solar Cells Applying the Passivated Emitter and Rear Cell (PERC) Concept—A Review," *IEEE J. Photovoltaics*, vol. 6,

no. 5, pp. 1366–1381, Sep. 2016.

- [21] J. Haschke, O. Dupré, M. Boccard, and C. Ballif, "Silicon heterojunction solar cells: Recent technological development and practical aspects - from lab to industry," *Sol. Energy Mater. Sol. Cells*, vol. 187, pp. 140–153, Dec. 2018.
- [22] E. Van Kerschaver and G. Beaucarne, "Back-contact solar cells: a review," *Prog. Photovoltaics Res. Appl.*, vol. 14, no. 2, pp. 107–123, Mar. 2006.
- [23] Frank Feldmann Sebastian Mack *et al.*, "Towards industrial manufacturing of TOPCon," *Photovoltaics Int.*, vol. 40.
- [24] R. Kopecek and J. Libal, "Towards large-scale deployment of bifacial photovoltaics," *Nat. Energy*, vol. 3, no. 6, pp. 443–446, Jun. 2018.
- [25] J. Haschke *et al.*, "The impact of silicon solar cell architecture and cell interconnection on energy yield in hot & sunny climates," *Energy Environ. Sci.*, vol. 10, no. 5, pp. 1196–1206, 2017.
- [26] ITRPV, "International Technology Roadmap for Photovoltaic 9th Edition," 2018.
- [27] S. Braun, G. Hahn, R. Nissler, C. Pönisch, and D. Habermann, "Multi-busbar Solar Cells and Modules: High Efficiencies and Low Silver Consumption," *Energy Procedia*, vol. 38, pp. 334–339, 2013.
- [28] [Cello Technology™ for LG NeON® 2 PV modules. Available at: http://www.lg.com/global/business/download/resources/solar/CT\\_NeON2.pdf"LG Neon2 datasheet."](http://www.lg.com/global/business/download/resources/solar/CT_NeON2.pdf)
- [29] A. et al Faes, "SmartWire Solar Cell Interconnection Technology," in *29th EU-PVSEC*, 2014.
- [30] S. H. et Al., "The Real Power of SmartWire Connection Technology," in *Presentation at SNEC 2018*, 2018.
- [31] T. Geipel, M. Moeller, A. Kraft, and U. Eitner, "A Comprehensive Study of Intermetallic Compounds in Solar Cell Interconnections and their Growth Kinetics," *Energy Procedia*, vol. 98, pp. 86–97, Nov. 2016.
- [32] J. Geissbühler, A. Faes, A. Lachowicz, C. Ballif, and M. Despeisse, "Metallization techniques and interconnection schemes for high efficiency silicon heterojunction PV," *PVTech*, 2017.
- [33] T. Borgers *et al.*, "A woven fabric for interconnecting back-contact solar cells," *Prog. Photovoltaics Res. Appl.*, vol. 25, no. 7, pp. 569–582, Jul. 2017.
- [34] [DuPont™, Tedlar® Polyvinyl Fluoride \(PVF\) Films. Available at: https://www.dupont.com/content/dam/dupont/products-and-services/membranes-and-films/pvf-films/documents/DEC\\_Tedlar\\_GeneralProperties.pdf"Solar panel applications."](https://www.dupont.com/content/dam/dupont/products-and-services/membranes-and-films/pvf-films/documents/DEC_Tedlar_GeneralProperties.pdf)
- [35] [Arkema™, Kynar® PVDF Fluoropolymer Family. Available at: https://www.extremematerials-arkema.com/en/product-families/kynar-pvdf-family/"Photovoltaic / Solar."](https://www.extremematerials-arkema.com/en/product-families/kynar-pvdf-family/)
- [36] [Cybrid™, KPF®. Available at: https://www.cybridtechnologies.com/kpf-difference/"Backsheets."](https://www.cybridtechnologies.com/kpf-difference/)
- [37] [Jingmao™, KPF-JM30®. Available at: http://en.jingmaosolar.com/products\\_detail/productId=37.html"Products and applications."](http://en.jingmaosolar.com/products_detail/productId=37.html)
- [38] [Jolywood™, Solar Module Backsheet FFC -JW30®. Available at: http://en.jolywood.cn/english.php/Product/detail/id/3/nid/2/sid/9"PV Materials."](http://en.jolywood.cn/english.php/Product/detail/id/3/nid/2/sid/9)
- [39] [Coveme™, Dymat®. Available at: http://www.coveme.com/dymat-](http://www.coveme.com/dymat)

- ~~range/]"Dymat Characteristics and product range."-~~
- [40] ~~Filmcutter™ Advanced Material, Filmback® MLP. Available at: [https://www.filmcutterpv.com/filmcutter-products/]"Filmback MLP."-~~
- [41] ~~Aluminum Feron™, Backsheet neoX® CPE. Available at: [https://www.feron.de/en/feron-solar/backsheet-neox-cpe/]"Feron."-~~
- [42] M. Koehl and others, "Round Robin testing of various back-sheets for PV-modules with different ultra-violet radiation sources and sample temperatures," 2015.
- [43] ~~DSM™ Endurance®, available at: [https://www.dsm.com/solutions/dsm-in-solar/en\_us/technologies/pv-backsheets.html]"PV Backsheets."-~~
- [44] ~~Agfa™ Unigoat®, available at: [http://www.agfa.com/specialty-products/solutions/solar-pv-backsheet/unigoat/]"AGFA."-~~
- [45] C. Peike and others, "Overview of PV module encapsulation materials," *Photovoltaics Int.*, 2013.
- [46] DSM, "Anti-Reflective coatings for solar glass." .
- [47] S. Oktik, "Photovoltaic Industry & Role of Glass for Reducing the Cost of Solar Energy Photovoltaic Industry and Role of Glass for Reducing Cost of Solar Energy President of Research and Technological Development Group," 2013.
- [48] C. X. et Al., "Failure Analysis to Identify Thermal Runaway of Bypass Diodes in Fielded Modules," in *NREL PV Module Reliability Workshop*, 2017.
- [49] K. Kato, "PVREss: A research activity on reliability of PV systems from a user's viewpoint in Japan," *SPIE*, 2011.
- [50] J. A. Tsanakas, L. Ha, and C. Buerhop, "Faults and infrared thermographic diagnosis in operating c-Si photovoltaic modules: A review of research and future challenges," *Renew. Sustain. Energy Rev.*, vol. 62, pp. 695–709, 2016.
- [51] J.A. Tsanakas et al., "Early Reliability Issues and Symptoms Evaluated in Four Large PV Plants in Southern France," in *NREL PV Module Reliability Workshop*, 2017.
- [52] D. Dirnberger and others, "PV module energy rating: opportunities and limitations," *Prog. Photovolt Res. Appl*, vol. 23, pp. 1754–1770, 2015.
- [53] Pv. SA, "PVsyst software Package." .
- [54] D. King and others, "Photovoltaic Array Performance Model," *Sandia Natl. Lab. Report, SAND*, pp. 2004–3535, 2004.
- [55] B. Bourne, *PVSim and Solar Energy System Performance Modeling*. White Paper © SUNPOWER Inc, 2009.
- [56] S. Armstrong and others, "A thermal model for photovoltaic panels under varying atmospheric conditions," *Appl. Therm. Eng.*, vol. 30, 2010.
- [57] G. T. et al., "Thermal models for PV modules in the BIPV applications," in *25th EU-PVSEC*, 2010.
- [58] H. Tain and others, "A cell-to-module-to-array detailed model for photovoltaic panels," *Sol Energy*, vol. 86, 2012.
- [59] G. Makrides and others, "Energy yield prediction errors and uncertainties of different photovoltaic models," *Prog Photovolt Res Appl*, vol. 21, 2013.
- [60] H. Goverde and others, "Optical-thermal-electrical model for a single cell PV module in non-steady-state and non-uniform conditions built in SPICE," in *28th EU-PVSEC*, 2013.
- [61] H. Goverde and others, "Energy yield prediction model for PV modules including

Formatted: French(France)

- spatial and temporal effects," in *29th EU-PVSEC*, 2014.
- [62] D. Anagnostos and others, "PV energy yield nowcasting combining sky imaging with simulation models," in *30th EU-PVSEC*, 2015.
- [63] H. Goverde and others, "Model requirements for accurate short term energy yield predictions during fast-varying weather conditions," in *30th EU-PVSEC*, 2015.
- [64] V. Sharma and others, "Performance and degradation analysis for long term reliability of solar photovoltaic systems: A review," *Renew. Sustain. Energy Rev.*, vol. 27, 2013.
- [65] I. E. C. 60068-2-78, "Environmental testing - Part 2-78: Tests - Test Cab: Damp heat, steady state."
- [66] IEC 61215, "Crystalline silicon terrestrial photovoltaic (PV) modules: Design qualification and type approval."
- [67] UL 1703, "Flat-Plate Photovoltaic Modules and Panels."
- [68] ASTM E1171, *Test Methods for Photovoltaic Modules in Cyclic Temperature and Humidity Environments*.
- [69] DeGraaff et al., "Degradation Mechanisms in Si Module Technologies Observed in the Field; Their Analysis and Statistics," in *PV Module Reliability Workshop*, 2011.
- [70] D. C. Jordan and S. R. Kurtz, "Photovoltaic degradation rates - An Analytical Review," *Prog. Photovoltaics Res. Appl.*, vol. 21, no. 1, pp. 12–29, 2013.
- [71] A. Phinikarides, N. Kindyni, G. Makrides, and G. E. Georghiou, "Review of photovoltaic degradation rate methodologies," *Renew. Sustain. Energy Rev.*, vol. 40, pp. 143–152, 2014.
- [72] M. Köntges et al., *Review of Failures of Photovoltaic Modules*. 2014.
- [73] A. Golnas, "PV System Reliability: An Operator's Perspective," *IEEE J. Photovoltaics*, vol. 3, no. 1, pp. 416–421, Jan. 2013.
- [74] S. Kurtz and others, "Technical report on photovoltaic module reliability workshop," 2013.
- [75] [SOLAR-TRAIN Project funded by the European Union's Horizon 2020 programme under GA. No. 721452, coordinated by the Fraunhofer Institute for Solar Energy Systems ISE \[https://solar-train.eu/\]"Solar-train."](https://solar-train.eu/)
- [76] ["SOPHIA EU FP7 Research Infrastructures funded by the European Union's Horizon 2020 programme under GA. No. 262533 \[http://www.sophia-ri.eu/\]"Sophia E. U. Research Infrastructures."](http://www.sophia-ri.eu/)
- [77] [W. Cole et al. \(2017\), SunShot 2030 for Photovoltaics \(PV\): Envisioning a Low-cost PV Future, Technical Report NREL/TP-6A20-68105"SunShot Initiative."](https://www.nrel.gov/pv/pv-future/)
- [78] "Iea-pvps Task, 13."
- [79] M. Köntges and others, "Assessment of Photovoltaic Module Failures in the Field. Report IEA PVPS Task 13 – ST3," 2017.
- [80] "PVQAT - International Photovoltaic Quality Assurance Task Force."
- [81] A. Mikofski and others, "An Integrated Model for Predicting PV Performance Degradation over 25+ Years," in *38th IEEE Photovoltaic Specialists Conference*, 2012.
- [82] A. Mikofski and others, "SunPower® Module 40-year Useful Life. White Paper © SUNPOWER Inc," 2013.
- [83] [PV CYCLE, Recycling of PV modules. \[http://www.pvcycle.org/pvcycle\\_document/recycling-of-pv-modules/\]"PV Cycle."](http://www.pvcycle.org/pvcycle_document/recycling-of-pv-modules/)

- [84] S. Weckend, A. Wade, and G. Heath, "End-of-life management - Solar photovoltaic panels," 2016.
- [85] J. R. Duflou, J. R. Peeters, D. Altamirano, E. Bracquene, and W. Dewulf, "Demanufacturing photovoltaic panels: Comparison of end-of-life treatment strategies for improved resource recovery," *CIRP Ann.*, vol. 67, no. 1, pp. 29–32, 2018.
- [86] K. Komoto *et al.*, *End-of-life management of photovoltaic panels: Trends in PV module recycling technologies*, 2018.
- [87] P. Cycle, "Annual Report 2016," 2016.
- [88] Veolia SA, article available at: [\[https://www.veolia.com/en/newsroom/news/recycling-photovoltaic-panels-circular-economy-france\]](https://www.veolia.com/en/newsroom/news/recycling-photovoltaic-panels-circular-economy-france) "Modules Recycling."
- [89] A. Hoke, A. Nelson, B. Miller, F. Bell, and M. Mccarty, "Experimental Evaluation of PV Inverter Anti-Islanding with Grid Support Functions in Multi-Inverter Island Scenarios Experimental Evaluation of PV Inverter Anti-Islanding with Grid Support Functions in Multi-Inverter Island Scenarios," no. July, 2016.
- [90] DNV GL, "The German 50.2 Hz problem."
- [91] CivicSolar, "What is galvanically isolated?" .
- [92] SMA, "Criteria for Selecting a Residual-Current Device," vol. 410, pp. 1–11, 2005.
- [93] Cenergy Power, "String vs. Central Inverters: Choosing the Right Inverter for your Solar System," 2014. .
- [94] "Inverters datasheet from ABB, Fronius, SolarEdge, Growatt, SMA, CPS, ...." .
- [95] "Building America Case Study: Photovoltaic Systems with Module-Level Power Electronics (Fact Sheet), Technology Solutions for New and Existing Homes, Energy Efficiency & Renewable Energy (EERE)," 2015.
- [96] "Single Phase Inverters with HD-Wave Technology." .
- [97] "Microinverter family." .
- [98] "The APsystems Microinverter." .
- [99] E. G. de Andrade, H. A. de Oliveira, W. V. Ribeiro, R. C. de Barros, H. A. Pereira, and A. F. Cupertino, "Power losses in photovoltaic inverter components due to reactive power injection," in *2016 12th IEEE International Conference on Industry Applications (INDUSCON)*, 2016, pp. 1–7.
- [100] S. H. Shehadeh, H. H. H. Aly, and M. E. El-Hawary, "An overview of inverter topologies for photovoltaic electrical energy," in *2013 IEEE Electrical Power & Energy Conference*, 2013, pp. 1–8.
- [101] K. O. Armstrong, S. Das, and J. Cresko, "Wide bandgap semiconductor opportunities in power electronics," in *2016 IEEE 4th Workshop on Wide Bandgap Power Devices and Applications (WiPDA)*, 2016, pp. 259–264.
- [102] S. (ORCID:0000000280862377); Das, L. D. (ORCID:0000000190657767); Marlino, and K. O. Armstrong, "Wide Bandgap Semiconductor Opportunities in Power Electronics," 2017.
- [103] P. Hacke *et al.*, "A status review of photovoltaic power conversion equipment reliability, safety, and quality assurance protocols," *Renew. Sustain. Energy Rev.*, vol. 82, no. April 2017, pp. 1097–1112, 2018.
- [104] IEA PVPS, *Technical Assumptions Used in PV Financial Models. Review of Current Practices and Recommendations*. 2017.
- [105] T. J. Formica, H. A. Khan, and M. G. Pecht, "The Effect of Inverter Failures on the

Formatted: French(France)

- Return on Investment of Solar Photovoltaic Systems," *IEEE Access*, vol. 5, pp. 21336–21343, Sep. 2017.
- [106] C. W. Thurston, "Inverter quality and warranties more important to owners," *pv magazine*, 2017. .
- [107] Schneider Electric, "A Quantitative Comparison of Central Inverters and String Inverters in Utility-Scale Solar Systems in North America," Dec. 2016.
- [108] Z. Ni, X. Lyu, O. P. Yadav, and D. Cao, "Review of SiC MOSFET based three-phase inverter lifetime prediction," *Conf. Proc. - IEEE Appl. Power Electron. Conf. Expo. - APEC*, pp. 1007–1014, 2017.
- [109] I. Lillo-Bravo, P. González-Martínez, M. Larrañeta, and J. Guasumba-Codena, "Impact of Energy Losses Due to Failures on Photovoltaic Plant Energy Balance," *Energies*, vol. 11, no. 2, p. 363, 2018.
- [110] Stephan Liese, "Next-generation inverters," *PV Tech*, vol. 13, no. December, pp. 18–21, 2017.
- [111] European Commission, "Waste Electrical & Electronic Equipment (WEEE)." .
- [112] "[Fronius Symo Hybrid 5.0-3-SStabiliti™-Multiport.](#)" .
- [113] VDE, "Low Voltage DC."
- [114] "Stichting Gelijkspanning Nederland." .
- [115] P. Van Tichelen, D. Ectors, M. Stevens, L. W. Chung, and K. Peeters, "Preparatory Studies for Product Group in the Ecodesign Working Plan 2012-2014: Lot 8 - Power Cables Task 1 -7 report," 2015.
- [116] I. Zanetti et al., "Building Integrated Photovoltaics: Product Overview for solar building skins. Status Report 2017, SUPSI – Swiss BIPV Competence Centre," 2017.
- [117] P. Bonomo et al., "BIPV Products Overview for Solar Building Skin," in *Proc. 33rd EU-PVSEC*, 2017.
- [118] K. Sinapis et al, "BIPV REPORT 2013 State of the art in Building Integrated Photovoltaics. , Solar Energy Application Centre (SEAC)," 2013.
- [119] M. Mani and R. Pillai, "Impact of dust on solar photovoltaic (PV) performance: Research status, challenges and recommendations," *Renew. Sustain. Energy Rev.*, vol. 14, no. 9, pp. 3124–3131, Dec. 2010.
- [120] W. Herrmann, "Time evolution of PV soiling loss at test locations in different climates," in *Workshop on "Soiling Effect on PV Modules,"* 2016.
- [121] D. Picault et al., "Reducing Mismatch Losses in Grid-Connected Residential BIPV Arrays Using Active Power Conversion Components," in *25th EU-PVSEC*, 2010.
- [122] C. Deline et al., "A Performance and Economic Analysis of Distributed Power Electronics in Photovoltaic Systems. Technical Report NREL/TP-5200-50003, USA," 2011.
- [123] SolarEdge case study, "Optimizing BIPV in Apartment Buildings," 2015.

Formatted: Dutch (Netherlands)

## List of abbreviations ~~and definitions~~

BAPV	Building Attached Photovoltaics
BIPV	Building integrated photovoltaics
BIPV	Building Integrated Photovoltaics
BOS	balance of system
CdTe	Cadmium Telluride
CIGS	<u>Cadmium Indium Gallium Selenide</u>
cSi	Crystalline Silicon
DSSC	Dye sensitized solar cells
EoL	End of Life
GaN	<u>G</u> allium nitride
GPP	Green Public Procurement
IMD	Insulation Monitoring Device
MLPE	Module-level power electronic
MPPT	Maximum power point tracking
PID	Potential-induced degradation
PO	Polyolefines
PR	Performance ratio
PVB	Polyvinyl butyral
RCD	Residual current detector
SiC	Silicon carbide
TFPV	<u>T</u> hin-film PV
TPSE	Thermoplastic silicone
WBG	Wide bandgap semiconductors

## List of figures

<u>Figure 1. Record module efficiencies by NREL National Renewable Energy Laboratories, April 2019.....</u>	<u>4</u>
<u>Figure 2: Overview of various cells architectures: (a) Al-BSF, (b) PERC, (c,d) PERT, (e) SHJ, (f) bifacial SHJ [25].....</u>	<u>10</u>
<u>Figure 3: Typical structural layers in a c-Si PV module .....</u>	<u>11</u>
<u>Figure 4. Costs during operation and maintenance (CPN), repair costs (CPN<sub>failure fix</sub>) and performance losses (CPN<sub>never detected</sub>) for top 10 risks for PV modules of all system sizes. Source: Solar bankability, 2017 .....</u>	<u>12</u>
<u>Figure 5: The different PV backsheets configurations available today. (Source: S.K. Chunduri and M. Schmela, "Market Survey on Solar Backsheets 2018", Public Report TaiyangNews) .....</u>	<u>15</u>
<u>Figure 6: Comparison of the efficiency of different recycling approaches (Dufluou et al.) .....</u>	<u>22</u>
<u>Figure 7. Inverters components that fail, from PV System Reliability: An Operator's Perspective, Golnas and Voss, SunEdison .....</u>	<u>34</u>
<u>Figure 8. Costs during operation and maintenance (CPN), repair costs (CPN<sub>failure fix</sub>) and performance losses (CPN<sub>never detected</sub>) for top 10 risks for PV inverters of all system sizes. Source: Solar bankability, 2017 .....</u>	<u>37</u>
<u>Figure 9. System topologies for connecting PV modules and batteries. ....</u>	<u>38</u>
<u>Figure 10. PV output 5 kWp, battery capacity 3,7 kWh, load demand 5 MWh/a, feed-in tariff 12 ct/kWh, retail price 28 ct/kWh.....</u>	<u>39</u>
<u>Figure 11. Yearly expected mean specific yield (P50) and its exceedance probabilities (P10 and P90) for each year of the economic life of the project. Source: Solar bankability .....</u>	<u>44</u>
<u>Figure 12. Example of Risk Matrix for PV modules and inverters. Source: Solar bankability, 2017.....</u>	<u>45</u>
<u>Figure 13: Examples of small-sized (upper right/left images) and large-sized (lower right/left images) BIPV solar tiles [25].....</u>	<u>53</u>
<u>Figure 1: Overview of various cells architectures: (a) Al-BSF, (b) PERC, (c,d) PERT, (e) SHJ, (f) bifacial SHJ [16].....</u>	<u>11</u>
<u>Figure 2: Typical structural layers in a c-Si PV module .....</u>	<u>12</u>
<u>Figure 3: The different PV backsheets configurations available today. (Source: ©TaiyangNews 2017) .....</u>	<u>15</u>
<u>Figure 4: Examples of small-sized (upper right/left images) and large-sized (lower right/left images) BIPV solar tiles [16].....</u>	<u>36</u>

Formatted: DefaultParagraphFont

Formatted: DefaultParagraphFont

Formatted: DefaultParagraphFont

Formatted: DefaultParagraphFont



## List of tables

Table 1. Comparison of different state-of-art approaches for PV energy yield modelling.	19
Table 2 Base case and design options for the improvement of crystalline PV modules ..	24
Table 3. Design options for the improvement of thin film PV modules .....	28
Table 4 Frequency of failure tickets and associated energy loss for each general failure area [105] .....	<u>3534</u>
Table 5 Base Case 1 single phase string inverters and improvement options.....	<u>4139</u>
Table 6 Base Case 2 three phase string inverters and improvement options .....	<u>4140</u>
Table 7 Base Case 3 large central inverters and improvement options .....	<u>4240</u>
Table 8 PV monitoring system classifications and suggested applications (source: IEC 61724-1:2017).....	<u>4745</u>
Table 9 System level improvement options for a residential PV system .....	<u>5148</u>
Table 10 System level improvement options for a medium size commercial PV system .....	<u>5149</u>
Table 11 System level improvement options for a large utility scale system .....	<u>5249</u>
Table 12 Module characteristics .....	<u>5754</u>
Table 13 Extrapolated data from the PEF to a commercial PV module .....	<u>5855</u>

**Annexes**

**Annex 1. Title of annex**

CONSULTATION DRAFT

CONFIDENTIAL DRAFT

## **GETTING IN TOUCH WITH THE EU**

### **In person**

All over the European Union there are hundreds of Europe Direct information centres. You can find the address of the centre nearest you at: <http://europa.eu/contact>

### **On the phone or by email**

Europe Direct is a service that answers your questions about the European Union. You can contact this service:

- by freephone: 00 800 6 7 8 9 10 11 (certain operators may charge for these calls),
- at the following standard number: +32 22999696, or
- by electronic mail via: <http://europa.eu/contact>

## **FINDING INFORMATION ABOUT THE EU**

### **Online**

Information about the European Union in all the official languages of the EU is available on the Europa website at: <http://europa.eu>

### **EU publications**

You can download or order free and priced EU publications from EU Bookshop at: <http://bookshop.europa.eu>. Multiple copies of free publications may be obtained by contacting Europe Direct or your local information centre (see <http://europa.eu/contact>).

## JRC Mission

As the science and knowledge service of the European Commission, the Joint Research Centre's mission is to support EU policies with independent evidence throughout the whole policy cycle.



### EU Science Hub

[ec.europa.eu/jrc](https://ec.europa.eu/jrc)



@EU\_ScienceHub



EU Science Hub - Joint Research Centre



Joint Research Centre



EU Science Hub



Publications Office

doi: xx.xxxx/xxxx

ISBN xxx-xx-xx-xxxx-x